

# Model SW-HMI-32-N4X

# Model SW-HMI-32-N7

SmartWireless™ HMI Panel

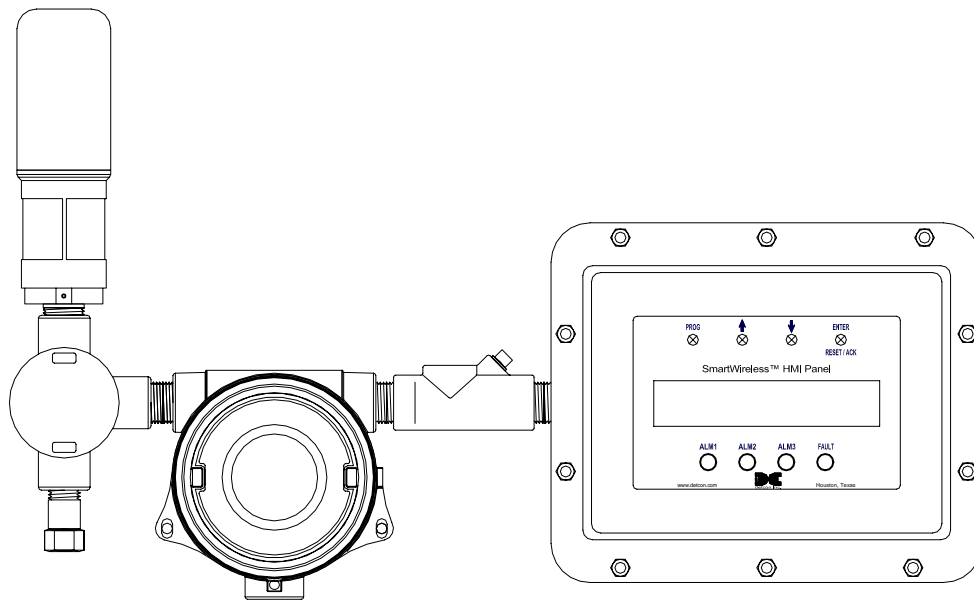

## Operator's Installation and Instruction Manual

Covers all Model SW-HMI-32 Remote Displays

◆ DETCON, Inc.  
4055 Technology Forest Blvd., Suite 100  
The Woodlands, Texas 77381  
Ph.281.367.4100 / Fax 281.298.2868

[www.detcon.com](http://www.detcon.com)

This page left intentionally blank

Shipping Address: 4055 Technology Forest Blvd., Suite 100, The Woodlands Texas 77381  
Mailing Address: P.O. Box 8067, The Woodlands Texas 77387-8067  
Phone: 888.367.4286, 281.367.4100 • Fax: 281.292.2860 • [www.detcon.com](http://www.detcon.com) • [sales@detcon.com](mailto:sales@detcon.com)

## Table of Contents

<b>1.0</b>	<b>Introduction.....</b>	<b>1</b>
1.1	Description .....	1
1.2	System Operation .....	2
1.3	RXT-300 Wireless Transceiver .....	2
1.4	Terminal Board and Smart Battery Pack (N7 Enclosure Only).....	3
1.5	Quad Battery Charger (Optional) .....	4
1.6	Solar Panel (Optional).....	5
1.7	RXT Wireless Configuration Tool (Optional).....	5
<b>2.0</b>	<b>Installation (N4X Enclosure) .....</b>	<b>6</b>
2.1	Mounting .....	6
2.2	Power & Modbus Connections.....	6
2.2.1	AC Power Input .....	6
2.2.2	DC Power Input.....	7
2.2.3	Modbus and DC Power Output .....	7
<b>3.0</b>	<b>Installation (N7 Enclosure) .....</b>	<b>9</b>
3.1	Mounting .....	9
3.2	Modbus & Power Connections.....	9
3.3	Optional Remote Alarm Reset/Acknowledge Switch (N7 Enclosure).....	11
<b>4.0</b>	<b>Initial Start-up .....</b>	<b>12</b>
<b>5.0</b>	<b>System Operation and Configuration .....</b>	<b>12</b>
5.1	Operator Interface.....	12
5.1.1	PROG Switch.....	13
5.1.2	“↑” Up Arrow Switch.....	13
5.1.3	“↓” Down Arrow Switch .....	13
5.1.4	ENTER and RESET/ACK Switch .....	13
5.2	Main Display Functions .....	13
5.3	Menu Functions.....	14
5.3.1	Auto Configure System.....	16
5.3.2	Response Timeout & Interpoll Delay.....	16
5.3.3	RF Silence & Inhibit Timers .....	16
5.3.4	Alarm Test Mode.....	17
5.3.5	System Diagnostics .....	17
5.3.6	Display Settings .....	18
5.3.7	About System.....	18
<b>6.0</b>	<b>Warranty .....</b>	<b>18</b>
<b>7.0</b>	<b>Specifications.....</b>	<b>19</b>
<b>8.0</b>	<b>Spare Parts .....</b>	<b>20</b>
<b>9.0</b>	<b>Revision Log.....</b>	<b>20</b>

## Table of Figures

Figure 1	SW HMI Panel N4X Enclosure.....	1
Figure 2	SW HMI Panel N7 Assembly .....	2
Figure 3	Terminal Board .....	3
Figure 4	Smart Battery Pack.....	4
Figure 5	Quad Battery Charger.....	4
Figure 6	Solar Panel.....	5
Figure 7	RXT Wireless Configuration Tool .....	5
Figure 8	N4X Enclosure Dimensional Overview .....	6

Figure 9 AC/DC Inputs.....	7
Figure 10 SW HMI N4X Enclosure w/RXT-300 & Secondary SW HMI Panel.....	8
Figure 11 RS-485 & Power Output Wiring for SW HMI N4X.....	8
Figure 12 SW HMI Panel N7 Assembly Dimensions .....	9
Figure 13 SW HMI N7 Enclosure w/RXT-300 & Terminal Board.....	10
Figure 14 RS-485 & Power Output Wiring for SW HMI N7.....	10
Figure 15 Remote Switch Connections .....	11
Figure 16 Magnetic Programming Tool .....	12
Figure 17 Front Panel User Interface.....	13
Figure 18 Menu Flow Chart.....	15

## List of Tables

Table 1 Terminal Board Jumper Settings .....	11
--	----

# 1.0 Introduction

## 1.1 Description

The SmartWireless™ Human Machine Interface (SW HMI) panel is a read only remote display unit designed to operate with Detcon’s RXT-300 wireless transceivers. It consists of an SW HMI module which provides an operator interface to an RXT-300 network and displays real time status of all configured network devices up to a maximum of 32 devices. Devices can be sensors, alarm stations, repeaters and other remote displays.

The SW HMI panel utilizes a non-intrusive magnetic interface operated by a small programming magnet and displays the real time status of devices on a backlit LCD. In normal operation, the SW HMI panel provides real time display of device number, gas concentration, device tag and the status of other field devices like Detcon’s Smart Battery charge levels, network RF signal quality and various fault diagnostic conditions affecting either an individual field device or the network in general. The front panel LED indicators provide the status of a device’s three alarm levels (Alarm 1, Alarm 2 and Alarm 3) and fault. Command functions such as alarm test and radio silence are included as well as additional features such as alarm inhibit, alarm reset and alarm silence (acknowledge) functions.

The SW HMI module is available in a choice of two enclosures. The first enclosure type is the Model SW-HMI-32-N4X which is housed in a NEMA 4X water proof enclosure and has a built in power supply that takes in 110/220VAC and outputs 24VDC. External DC power (11.5-30VDC) can also be provided by the customer to power the remote display if AC power is not available or desired. This unit provides DIN rails which are used to mount the power supply and terminal blocks. The required RXT-300 wireless transceiver and custom terminal board (8-Position) will need to be purchased separately for this enclosure type.

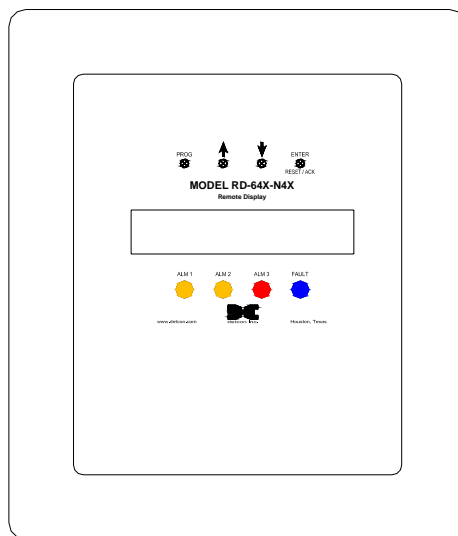

**Figure 1** SW HMI Panel N4X Enclosure

The second enclosure type is the Model SW-HMI-32-N7 which is housed in a NEMA 7 explosion proof aluminum panel enclosure. Due to this enclosure type, the unit’s internal space is limited and cannot support a built in power supply or DIN rails. It comes preassembled with an RXT-300 wireless transceiver and derives its power from a Smart Battery Pack enclosed in an aluminum conduit with a custom terminal board, all installed on a custom mounting plate. The SW HMI’s advanced design takes advantage of a low

power LCD with back light and ultra low power components that extend operating time for 1-2 months before a recharge is required. Additionally, an optional solar charging panel can be used to extend operating time for virtually any application.

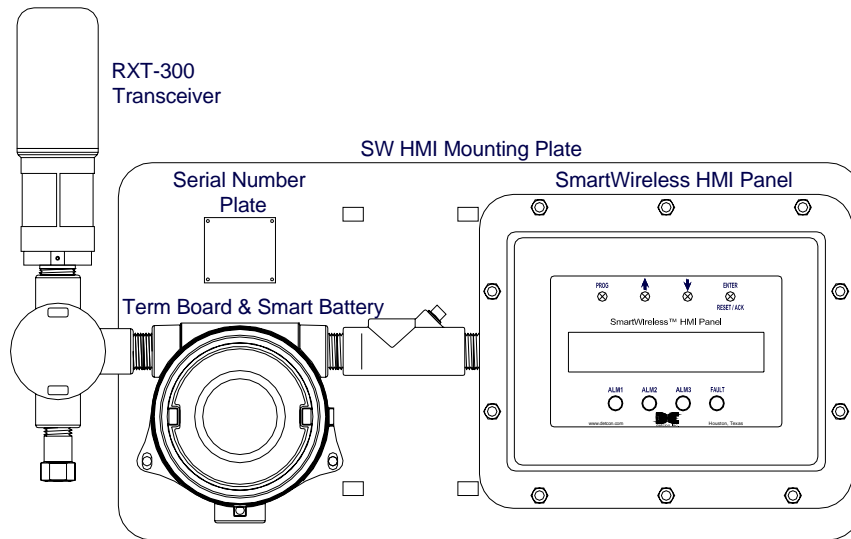

**Figure 2** SW HMI Panel N7 Assembly

## 1.2 System Operation

The heart of the SW HMI is the non-intrusive magnetic interface with backlit LCD display. The display receives real time data from RXT-300s using RS-485 Modbus™ RTU protocol. The SW HMI includes a primary Modbus™ interface (COMM1 Master) used to receive concentration and status directly from the RXT-300 transceiver (Slave) being monitored. A secondary Modbus™ interface (COMM2 Slave) is also available which is used for communication with another remote display where the SW HMI is seen as a slave device. The SW HMI panel only monitors the network and does not perform the actual polling of sensors and processing of alarms. It only provides the user a visual status of the system including fault conditions and managing of alarm events such as alarm inhibit/reset/silence. Wiring of an external manual switch is also available to act as an Acknowledge/Reset button. This switch comes preinstalled for the N4X enclosure and is optional for the N7 enclosure (See section 3.3 Optional Remote Alarm Reset/Acknowledge Switch (N7 Enclosure)).

## 1.3 RXT-300 Wireless Transceiver

The wireless function of the SW HMI panel is made possible by Detcon’s RXT-300 wireless transceiver. This transceiver transmits signal data such serial Modbus™ and can support up to 32 devices. It operates at 2.4GHz and conforms to non-licensed radio frequency appliance usage around the world. Wireless network integrity and security is accomplished using direct sequence spread spectrum wireless mesh technology. Wireless applications can be as simple as a single field device communicating with an SW HMI panel or any number of field devices forming a network of subscribers. Every device in the network is capable of functioning as a router and repeater for all other devices in the network. This means that subscribers can “hop” through neighboring devices to communicate with each other thereby widening network access points. This unique and innovative technology is designed to create a robust network that automatically routes around congestion and line-of-sight obstacles while improving throughput as subscriber device density increases. The RXT-300 also provides a network wide control processing capability. Refer to its instruction manual for more detailed information.

## 1.4 Terminal Board and Smart Battery Pack (N7 Enclosure Only)

The Model SW-HMI-32-N7 panel assembly comes with a custom terminal board (5143) and smart battery pack mounted inside an aluminum conduit. The terminal board includes connector plugs for the following:

- J1: 6-Pin Phoenix Connector – RXT-300 Wireless Transceiver (Power, Modbus™ & I<sup>2</sup>C)
- J2: 5-Pin Phoenix Connector – SW HMI Panel (Power & Modbus™)
- J3: 6-Pin Header – RXT-300 Programming Port (Detcon Factory use only)
- J4: 3-Pin Phoenix Connector – Not Used
- J5: 3-Pin Phoenix Connector – External DC Power In (11.5-30VDC)
- J6: 8-Pin Beau Connector – Smart Battery Pack
- J7: 3-Pin Phoenix Connector – Not Used
- J8: 3-Pin Phoenix Connector – Programming Interface to RXT-300 Wireless Transceiver

Refer to section 3.2 Modbus & Power Connections for more information about the setup of the terminal board.

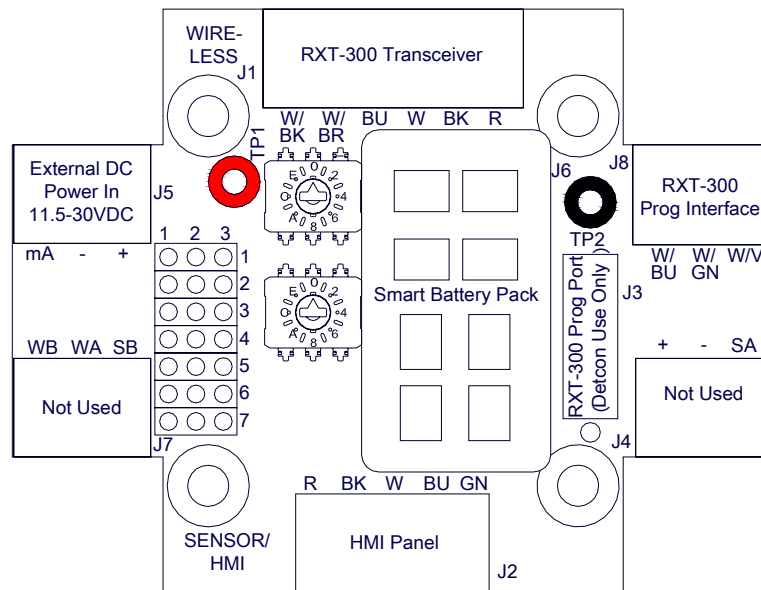

**Figure 3** Terminal Board

The available battery pack for the SW HMI panel N7 assembly is Detcon’s plug-in Smart Battery Pack which provides an output of 12VDC and allows the assembly to be remotely mounted without the need for any cables because of its wireless operation (See Figure 4). If installed, the RXT-300 transceiver will detect the battery and will continuously query the battery pack for remaining battery life. The battery pack consists of rechargeable Lithium-Ion batteries and is equipped with integrated safety electronics that include fuel gauge, voltage, current and temperature monitoring circuits. This “smart” circuitry continuously monitors the battery’s condition and reports critical status information to the wireless transceiver via the Modbus™ registers. The battery pack is designed to plug onto an 8-pin Beau connector on the terminal board and should not be exposed to outside elements without being housed and protected. Only Detcon products specifically designed to utilize these battery packs should be used. Operating periods before recharge will vary based on devices attached along with the transceiver and the usage of those devices, but can be as long as 2-3 months and battery life can be up to 5 years before battery pack replacement is required. Improper use of the battery pack may be hazardous to personnel or the environment and will void the warranty.



**Figure 4** Smart Battery Pack

---

**NOTE:** The SW HMI panel can also be powered by a customer provided external DC power source on connector J5 of the terminal board with a voltage range of 11.5-30VDC.

---

### 1.5 Quad Battery Charger (Optional)

Detcon’s Smart Battery Pack can be charged as needed using Detcon’s optional Quad Battery Charger which can charge up to four battery packs at one time. The Quad Battery Charger comes with a plug-in AC/DC adapter that plugs into a standard 120VAC outlet for power. The DC end of the adapter plugs into the DC power jack of the charger providing 24VDC. The Quad Battery Charger has four charging ports, each with 8-pin Beau connectors for battery pack connection. The ports and connectors are keyed to prevent incorrect positioning and connection. Each port has its own “FAULT” LED indicator and “CHARGE” LED indicator and will display either a red light or green light depending on the status of each battery being charged. Charging times will vary depending on the charge state of each battery pack, but a full charge of a depleted battery pack can take up to 24 hours.



**Figure 5** Quad Battery Charger

When first powered on and with no battery packs connected to the charger, all the LED indicators on the Quad Charger should be green. When a battery pack is seated into a charging port, the “CHARGE” LED will change from green to red indicating the battery pack is not sufficiently charged. Once fully charged, the LED will change from red to green and the battery pack is ready to be used.

The “Fault” LED should remain green indicating that there are no problems with the battery pack or charging port. If the “Fault” LED turns red with the battery pack connected, then there is a problem or issue with the battery pack and it should not be used and be removed immediately. If the “Fault” LED

turns red without a battery pack connected to the charge port, then there is a problem or issue with the port and that port should no longer be used.

Battery packs can remain connected to the charger even after a full charge indication (Green “Charge” LED) is shown due to the protection circuitry of the battery pack which prevents any overcharging issues.

### 1.6 Solar Panel (Optional)

Detcon also offers an optional solar panel to be used in conjunction with the Smart Battery Pack. It provides 24VDC output and connects to the J5 connector of the terminal board. This option enables continuous operation of the HMI panel and charging of the battery pack eliminating the need for external recharging. It is an ideal choice for virtually any area with sufficient daily average sunlight. Since the solar panel is considered an external power supply, a special conduit installation will be required.

If the optional solar panel is installed, consideration should be given to position the panel where the most sunlight is available. The solar panel can be mounted remotely to allow for maximum sunlight exposure. If necessary, a sunshade can be used for the HMI panel assembly to help reduce its operating temperature.



Figure 6 Solar Panel

### 1.7 RXT Wireless Configuration Tool (Optional)

The RXT Wireless Configuration Tool (WCT) is an optional device designed to configure Detcon’s RXT-300 transceivers. The WCT is used to configure and change the wireless channel on a collection of RXT transceivers and to configure RXT-300 wireless networks which interface with the SW HMI panel assembly.

The RXT WCT is a lightweight and powerfully equipped device with a 10.1” touch panel widescreen LCD for display and user input. It interfaces with a USB wireless radio that enables communication with wireless radios of the same type installed in RXT-300 transceivers allowing for their configuration. It can be powered by 100-240VAC with the supplied AC adapter or operate off of the internal rechargeable battery for up to 8 hours on a single charge. Refer to its instruction manual for more detailed information.



Figure 7 RXT Wireless Configuration Tool

## 2.0 Installation (N4X Enclosure)

### 2.1 Mounting

Securely mount the Model SW-HMI-32-N4X per the mounting dimensions provided in Figure 8. Provide for suitable conduit/cable entries in the bottom, top or sides of the enclosure and use required cable glands to maintain enclosure rating. Keep AC power separate from DC power and signals within conduit runs.

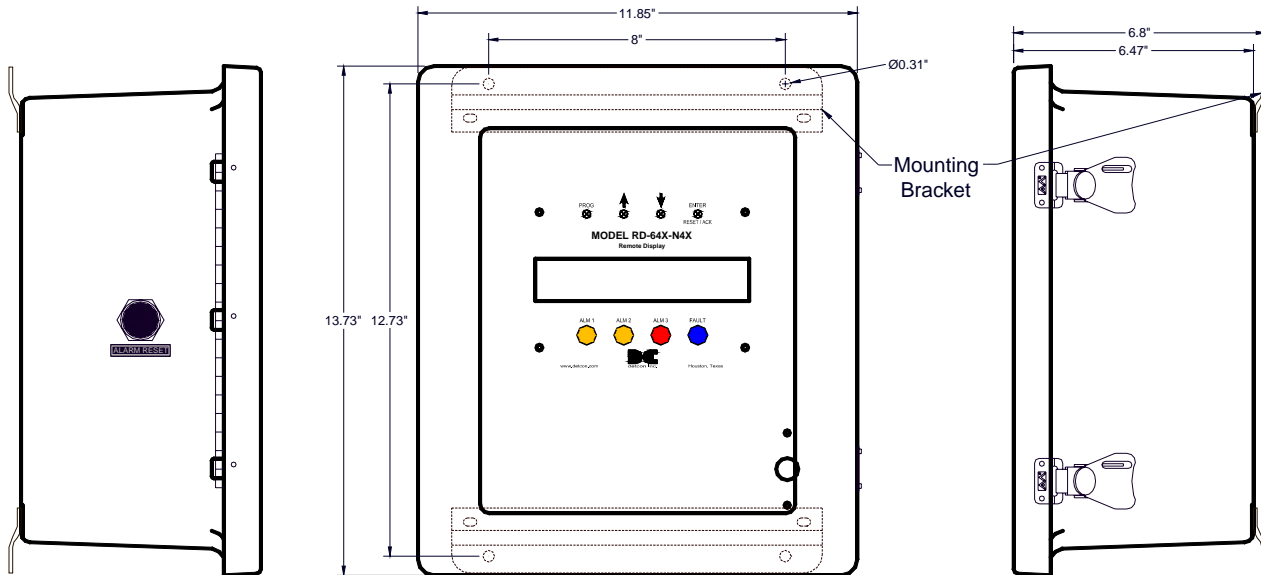

Figure 8 N4X Enclosure Dimensional Overview

### 2.2 Power & Modbus Connections

The SW-HMI-32-N4X remote display can be powered by either 110/220VAC or 11.5-30VDC. An internal power supply is available for the SW-HMI-32-N4X that converts 110/220VAC to 24VDC (up to 2.5 Amps) and can power an RXT-300 transceiver plus up to eight serial sensors. Optionally, the SW-HMI-32-N4X can be powered by an external DC power source that meets the input requirements of the unit if AC power is not available or desired.

The SW-HMI-32-N4X remote display includes a primary Modbus™ interface (COMM1 Master) used to receive concentration and status directly from its RXT-300 transceiver (Slave) as well as a secondary Modbus™ interface (COMM2 Slave) which is used for communication with another remote display where the SW HMI is seen as a slave device.

#### 2.2.1 AC Power Input

Connect 110/220VAC input wiring to the terminals of the DIN rail mounted terminal block labeled “VAC (L1)”, “NEU (L2)”, and “GROUND” (See Figure 9). The power supply for the SW-HMI-32-N4X is capable of handling AC inputs from 100-240VAC, 45-65Hz without degradation and can power up to eight serial sensors.

**NOTE:** The input voltage range must be between 100-240VAC. All wired Modbus™ devices connected to the SW-HMI-32-N4X must have a common ground.

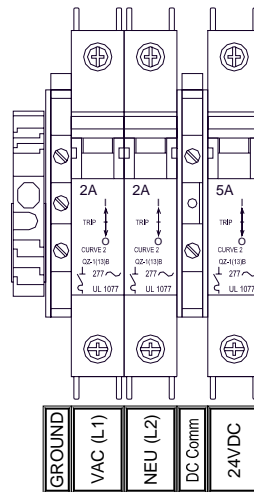

Figure 9 AC/DC Inputs

### 2.2.2 DC Power Input

For optional external DC power input, connect 11.5-30VDC to the terminals of the DIN rail mounted terminal block labeled “24VDC” and “DC Comm” (See Figure 9). This input can be used for primary power or back-up power in the event of an AC power failure. The DC input voltage source should be capable of delivering at least 2.5 Amps of current to the load (60 Watts @ 24VDC) which will power an RXT-300 transceiver plus up to eight serial sensors.

---

**NOTE:** The supply of power should be from an isolated source with over-current protection. The input voltage range must be between 11.5-30VDC. **All wired Modbus™ devices connected to the SW-HMI-32-N4X must have a common ground.**

---

### 2.2.3 Modbus and DC Power Output

The serial RS-485 (Modbus™) and power to the RXT-300 (Slave) being monitored by the SW-HMI-32-N4X remote display (COMM1 Master) is provided through the terminals of the DIN rail mounted terminal block labeled “RS-485 MASTER” and “VDC Out” (See Figure 11). The serial RS-485 connection labeled “RS-485 SLAVE” is used to connect to another remote display where the SW-HMI-32-N4X will be seen as a slave device in that specific Modbus™ loop. RS-485 connections require 24 AWG, two conductor, shielded, twisted pair cable. Belden P/N 1502P is recommended for a single cable providing both serial communications and power. Belden P/N 9841 is recommended for a single cable providing serial communications only. For the N4X enclosure, the RXT-300 transceiver, terminal board (8-Position) and conduit assembly are ordered separately.

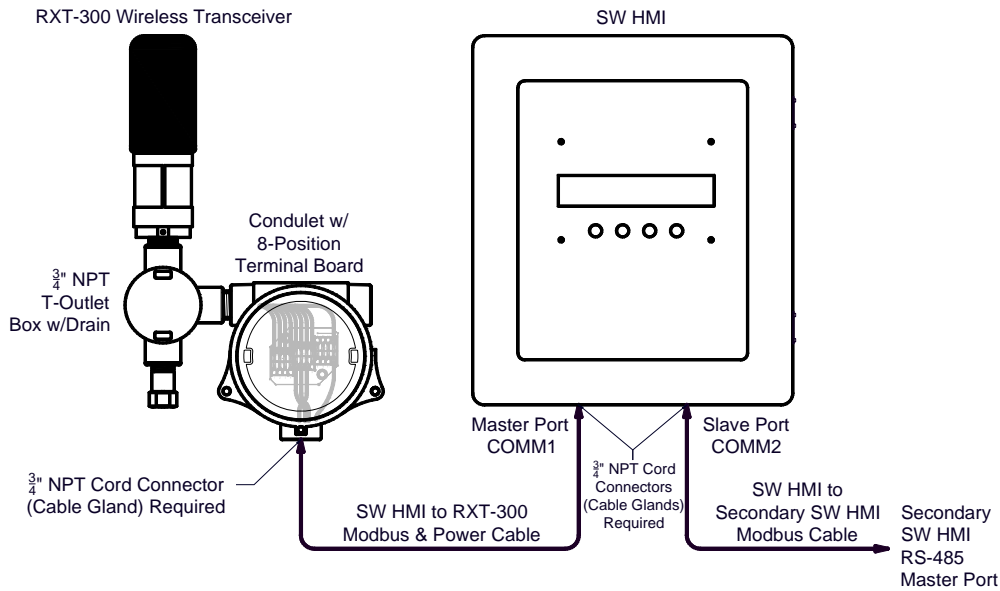

Figure 10 SW HMI N4X Enclosure w/RXT-300 & Secondary SW HMI Panel

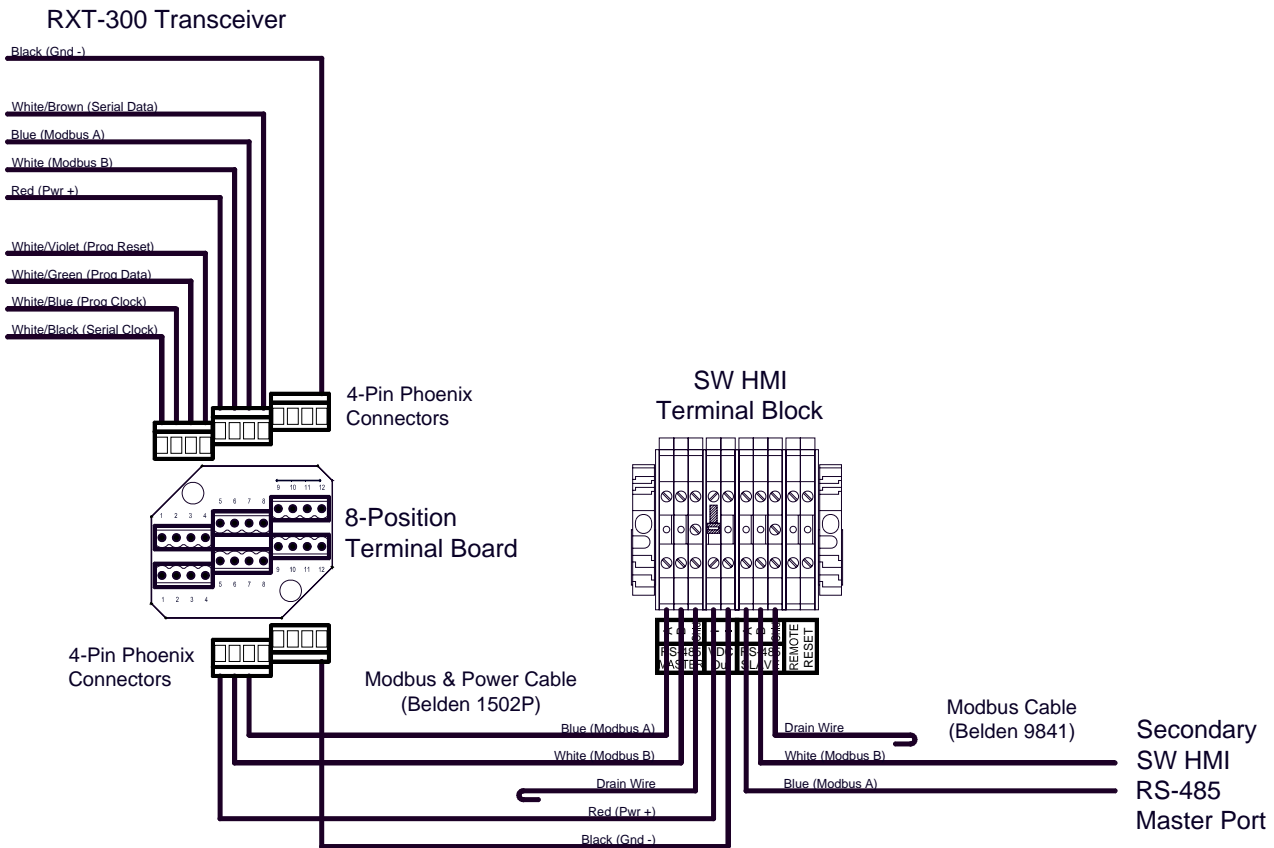

Figure 11 RS-485 & Power Output Wiring for SW HMI N4X

**NOTE:** Ground the cable shielding (drain wire) at the SW HMI only. Other points of grounding may cause a ground loop and induce unwanted noise on the RS-485 line which may disrupt communications.

## 3.0 Installation (N7 Enclosure)

### 3.1 Mounting

The Model SW-HMI-32-N7 panel comes assembled with an RXT-300 transceiver and a Smart Battery Pack enclosed in an aluminum condulet with a custom terminal board. This assembly is attached to a custom mounting plate making installation simple and easy onto a rigid pipe or structure with the two 2 1/2" U-bolts provided (refer to Figure 12).

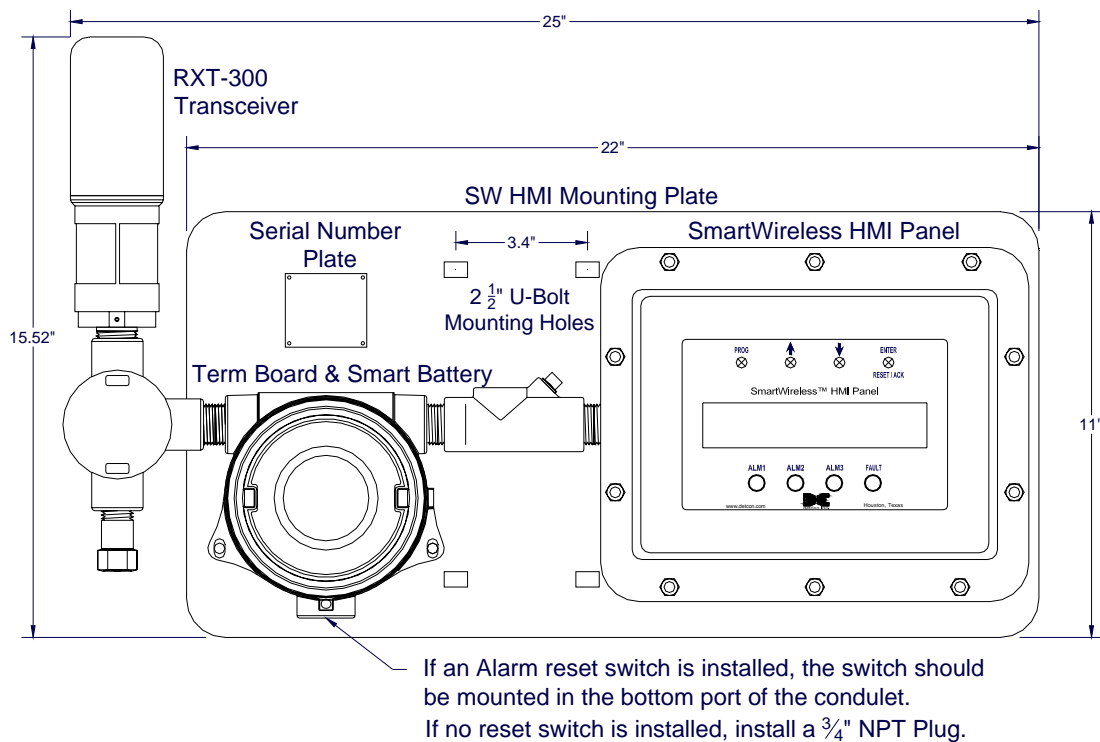

**Figure 12** SW HMI Panel N7 Assembly Dimensions

### 3.2 Modbus & Power Connections

Power to the SmartWireless™ HMI panel assembly in the N7 enclosure is provided by Detcon’s Smart Battery Pack supplying +12VDC to the RXT-300 transceiver and the SW HMI panel. The Smart Battery Pack plugs into the custom terminal board which resides inside the aluminum condulet. This terminal board has separate plug-in connectors available for the transceiver and panel through which power and I/O connections are made (refer to Figure 13 ). The term board and battery pack can be easily accessed by removing the condulet lid.

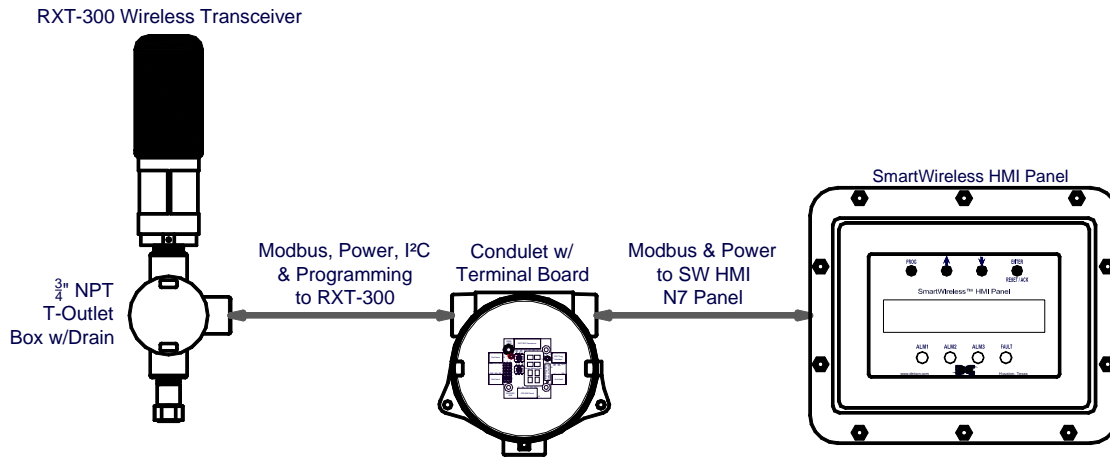

Figure 13 SW HMI N7 Enclosure w/RXT-300 & Terminal Board

Power and I/O connections from the terminal board to the HMI panel are made on the J7 connector of the HMI PCA (refer to Figure 14). Plug-in connectors are provided for input wiring terminations. This connector style provides for quick disconnect convenience during replacement or servicing. To access J7, remove the faceplate from the HMI panel enclosure to reveal the HMI PCA.

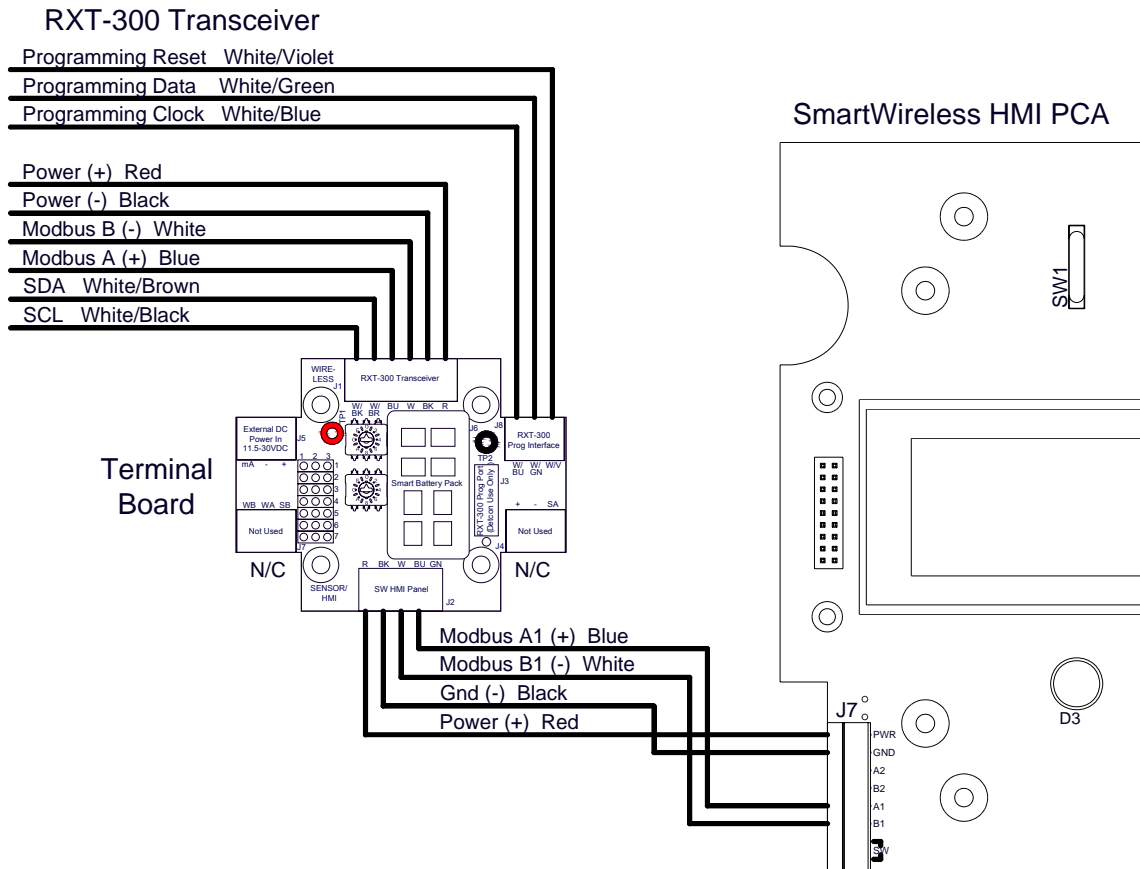

Figure 14 RS-485 & Power Output Wiring for SW HMI N7

The wiring for the J7 connector is defined as follows,

- PWR/GND: DC power connection from J2 of the terminal board. (11.5-30VDC)
- A1/B1: Primary Modbus™ connection (COMM1 Master) from J2 of the terminal board.
- A2/B2: Secondary Modbus™ connection (COMM2 Slave) to another remote display.  
\*Contact Detcon for wiring instructions when using the A2/B2 pin outs\*
- SW: External switch connection for RESET/ACK function. (Normally Open)

The terminal board contains a set of jumpers that must be configured properly for the board to operate properly. These jumpers are normally configured at the factory and should not be changed. Misplacement of these jumpers may cause the wireless transceiver to become inoperative. The following table identifies the jumper positions.

**Table 1** Terminal Board Jumper Settings

Jumper	Position
JP1	2-3
JP2	1-2
JP3	1-2
JP4	1-2
JP5	1-2
JP6	1-2
JP7	1-2

### 3.3 Optional Remote Alarm Reset/Acknowledge Switch (N7 Enclosure)

The Model SW-HMI-32-N4X panel display comes preinstalled with an external Remote Alarm Reset/Acknowledge switch located on the side of the enclosure. The Model SW-HMI-32-N7 remote display has the option of adding an external Remote Alarm Reset/Acknowledge switch. This enables the user to reset or acknowledge alarms external from the SW HMI without having to open the enclosure. The Reset Switch is a normally-open momentary contact push button type switch and will typically be mounted on the bottom of the condulet which houses the Smart Battery pack for the N7 enclosure. Connect the switch (SW1) to the terminals “SW” on connector J7 of the SW HMI PCA (See Figure 15). Once installed, pushing the switch will execute the reset/acknowledge function.

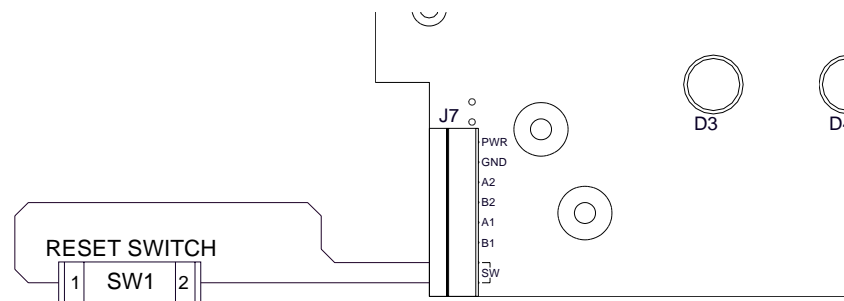

**Figure 15** Remote Switch Connections

## 4.0 Initial Start-up

The HMI display will power up as soon as power is applied. There is no external power switch to the unit.

---

**NOTE:** Before applying power, check to make sure that all the wiring connections and external devices are installed correctly.

---

---

**NOTE:** Applying power with devices hooked up incorrectly may cause damage to the equipment.

---

When power is applied to the unit, the unit will boot up and display the firmware version and proceed to sync with the network if a previous configuration exists. The firmware information will be shown as:

DETCON INC  
SMARTWIRELESS HMI PANEL  
VERSION #.##

If a previous configuration does not exist, the user will be prompted to auto configure the network from the HMI display. After the unit has been configured, the unit will begin normal operation. If the unit has been configured properly, the unit will display the current status of the devices that it is connected to. Reference section 5.3.1 for more information on auto-configure.

---

**NOTE:** The RXT-300 wireless transceiver interfaced to the HMI display must be properly configured prior to HMI configuration.

---

## 5.0 System Operation and Configuration

The setup of the wireless network is critical for proper operation. All RXT-300 transceivers in the network must be configured properly to allow the HMI to communicate with them.

### 5.1 Operator Interface

The operator interface of the HMI unit is accomplished via four internal magnetic switches located above the unit's backlit LCD display behind the glass cover. The four switches offer a non-intrusive interface and allow for complete configuration of the HMI. These switches are labeled: PROG, "↑" (Up Arrow), "↓" (Down Arrow) and ENTER. The ENTER switch also doubles as a RESET/ACK switch from the Main Display only (Not in Menu Mode). With reference to the Menu Flow Chart (See Figure 18), it is easy to learn how to navigate the menus and make changes.

The magnetic programming tool (See Figure 16) is used to operate the magnetic switches. Switch action is defined as a momentary contact (hold) on a switch marker (⊗). For momentary contact, the programming magnet is briefly held above the switch marker (⊗) and then removed. This action will be referred to as a "swipe" for the remainder of this manual.



**Figure 16** Magnetic Programming Tool

### 5.1.1 PROG Switch

From the Main Display, the PROG switch enters into the Main Menu. Once inside the Main Menu, the PROG switch acts as an “Escape” switch that moves backwards in the menu flow chart.

---

**NOTE:** While in Main Menu mode there are no updates to gas readings and hence no alarms will take place.

---

### 5.1.2 “↑” Up Arrow Switch

This switch moves the user up the Main Menu flow chart. It is also used to change selected entries within menu selections in the upward direction.

### 5.1.3 “↓” Down Arrow Switch

This switch moves the user down the Main Menu flow chart. It is also used to change selected entries within menu selections in the downward direction.

### 5.1.4 ENTER and RESET/ACK Switch

This switch has multi-purpose uses. The ENTER function is used to accept selections within all menu screens. The switch is also used to execute the Reset and Acknowledge functions. The Reset function releases all latched relays if they have cleared the alarm/fault condition. The Acknowledge function will disengage any silenceable relays that are in a currently active state. This is typically used to silence alarms once the end-user has assessed the alarm condition. The RESET/ACKNOWLEDGE function of the switch is only applicable from the Main Display and not while in Main Menu mode.

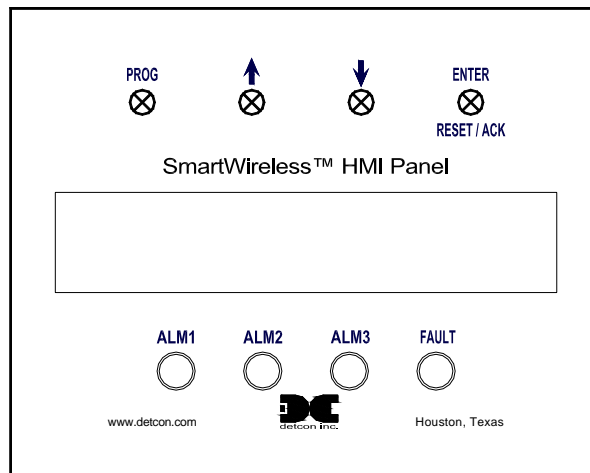

**Figure 17** Front Panel User Interface

---

**NOTE:** The controller automatically times out of Main Menu mode and returns to the Main Display after 15 seconds of inactivity.

---



---

**NOTE:** The RESET/ACKNOWLEDGE function is applicable from the Main Display only.

---

## 5.2 Main Display Functions

The Main Display is a 1¼” x 6” backlit LCD that has 4 lines by 40 characters. The HMI will group sensors separately from all other devices displaying sensors first, then all other devices by their configuration order. In normal operation, the configured sensors will be displayed up to 4 at one time. The LCD then refreshes,

displaying the next 4 sensors and so on. The HMI will then proceed to display all other devices on the network such as alarm stations, repeaters and other HMIs including itself up to 4 at one time, until the LCD cycles back to the first 4 sensors and repeats the process. When the HMI is in alarm, the display will stay on the group with the device in alarm. If two or more devices in different groups are in alarm, then the display will cycle through all the groups with alarms. The user can manually advance to the next device group using the arrow switches. This is considered normal operation and each device's information will be shown as:

XX>   YYY “Device Tag” “Device Status” ZZZ%

**XX**       Represents the corresponding device number as defined by its configuration order.

**YYY**       Represents the gas concentration value for sensors. All other devices will display “-----”.

**Device Tag**   Represents the alphanumeric name given to the device during configuration for which only the first 15 characters are displayed. If the device is in any gas alarm condition, this field will display “IN ALARM #” for that device. If any device is in fault, this field will display “IN FAULT” for that device.

**Device Status** Represents the status of the device. For Smart Battery powered devices, this field will display the charge level as DD:HH:MM corresponding to days, hours and minutes remaining of the battery life. If the battery life is greater than 45 days, then the charge level will be displayed as a percentage. For alarm stations, this value will always be a percentage of the charge level. If an external DC source is used, “DC POWER” will be displayed. This field can also display “COM ERR” if any RXT is not communicating with its appropriate device or “OFFLINE” if the HMI is not communicating with an RXT.

**ZZZ**       Represents the network RF signal quality as a percentage.

Four LED indicators on the front panel show alarm and fault alarm output status. The LED's represent ALM 1 (yellow), ALM 2 (yellow), ALM 3 (red) and FAULT (blue) and are labeled respectively.

### 5.3 Menu Functions

The HMI unit setup is accomplished through the MAIN MENU. The MAIN MENU consists of 7 menu items:

- 1) AUTO CONFIGURE SYSTEM
- 2) RESPONSE TIMEOUT & INTERPOLL DELAY
- 3) RF SILENCE & INHIBIT TIMERS
- 4) ALARM TEST MODE
- 5) SYSTEM DIAGNOSTICS
- 6) DISPLAY SETTINGS
- 7) ABOUT SYSTEM

The PROG switch is used to enter the menu mode of the unit by swiping a programming magnet over the corresponding marker “⊗”. Once in the menus, all Modbus™ polling stops. Sensor values are not read and alarm outputs are not updated. If the HMI is in alarm when the user enters the menu, it will stay in alarm until they exit the menu. Upon entering the MAIN MENU, the LCD will display:

MAIN MENU

AUTO CONFIGURE SYSTEM

Use the down arrow “↓” switch to move to the next menu item or use the up arrow “↑” switch to move to the previous menu item by swiping the programming magnet over the corresponding markers. Swiping the PROG switch again will return the unit to normal operation. When the appropriate Menu Item is found, the ENTER switch is used to enter that menu item by swiping the ENTER marker.

**NOTE:** The HMI automatically times out of Main Menu mode and returns to the Main Display after 15 seconds of inactivity. While in Main Menu mode, there are no updates to gas readings.

**NOTE:** The LCD has a backlight that will automatically turn off after a user-defined amount of inactivity. The LCD backlight will come on automatically as soon as any magnetic switch is activated. This is a feature designed to save on power.

There are 7 Main Menu items and their functional descriptions are discussed in the following sections.

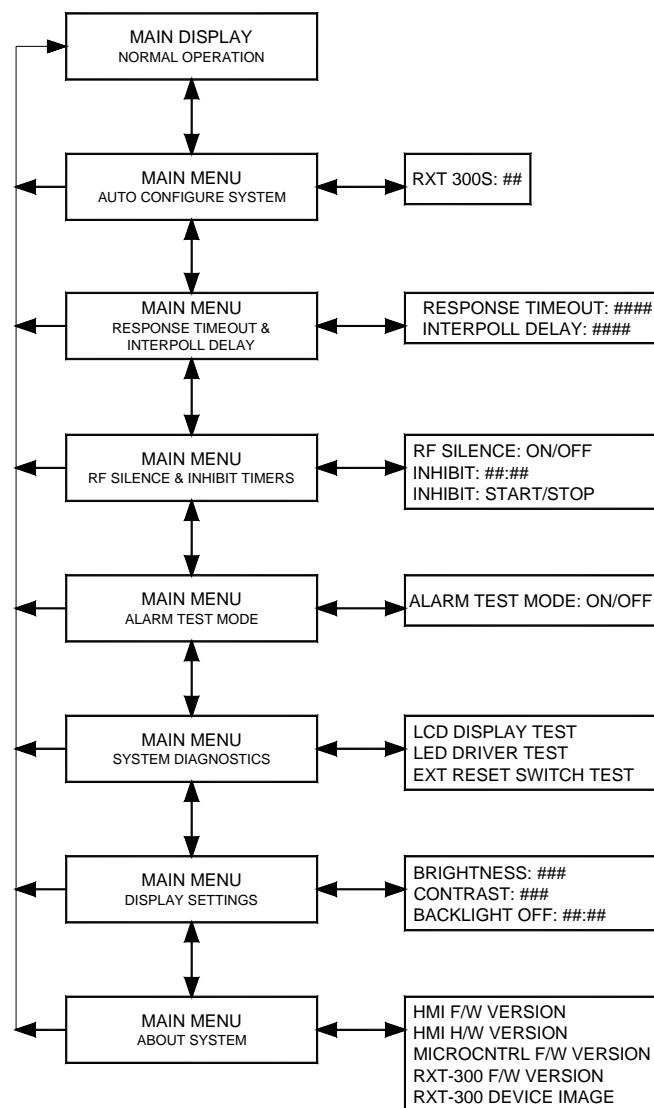

Figure 18 Menu Flow Chart

### 5.3.1 Auto Configure System

The AUTO CONFIGURE SYSTEM menu is used to automatically configure the HMI panel when a properly configured wireless network is available. When this feature is activated, the HMI will search for RXT-300 wireless transceivers in the configured network by polling their Modbus™ addresses. Upon entering this menu, the LCD will display:

AUTO CONFIGURE CHANNELS  
RXT ID:161  
SYSTEM CONFIGURED  
[RE-CONFIGURE]

The RXT ID number is the Modbus™ address of the RXT-300 transceiver being polled. The user has the option of re-configuring the network by performing a one second hold on the “ENTER” marker. The controller will automatically search for available RXT-300 transceivers and configure the HMI panel.

---

**NOTE:** The RXT-300 wireless network must be set up and configured properly using the Wireless Configuration Tool prior to performing an auto configure.

---

---

**NOTE:** The number of activated devices can be less than (but not greater than) the controller’s maximum input capacity. The maximum input capacity is 32 devices for Model SW-HMI-32.

---

---

**NOTE:** An auto configure must be performed each time the network configuration is changed.

---

### 5.3.2 Response Timeout & Interpoll Delay

The RESPONSE TIMEOUT & INTERPOLL DELAY menu displays the values for response timeout and interpoll delay of the HMI panel. Upon entering this menu, the LCD will display:

SET MODBUS TIMEOUTS:  
  
RESPONSE TIMEOUT:500  
INTERPOLL DELAY:100

Response timeout is the amount of time in milliseconds the HMI display will wait for an RXT-300 to respond to a poll request. Ten missed poll responses will result in the device being declared in COMM ERR. The range of values for the response timeout is 100-1000 milliseconds. The recommended value for the response timeout is 500.

Inter-poll delay is the minimum amount of time in milliseconds the HMI display waits before sending out another poll request to the next device. The range of values for the inter-poll delay is 10-255 milliseconds. The recommended value for the inter-poll delay is 100.

---

**NOTE:** The values shown are pre-programmed to 500 and 100 respectively and should not be altered unless directed to do so by Detcon Factory Personnel.

---

### 5.3.3 RF Silence & Inhibit Timers

The RF SILENCE & INHIBIT TIMERS menu allows the user to initiate RF (radio) silence over the whole network as well as inhibit functionality of alarms in the network. Radio silence terminates communication between all the RXT-300 transceivers in the network. The inhibit function disables all alarm and fault outputs on the network. Upon entering this menu, the LCD will display:

```

RF SILENCE & ALARM INHIBIT
RF SILENCE | INHIBIT:##:##
TURN: ON | OFF | START
# | # |

```

Select the function by swiping the magnet over the markers of the up or down arrows to move the arrow prompt “→” to the desired location. A swipe over the “ENTER” marker will activate the selected function.

RF SILENCE is used to prevent the radios from possibly interfering with other RF devices on site (such as remote detonators). Once set to ON, it will stay on until the user turns it OFF. The values below ON and OFF represent the number of RXTs that have RF silence turned ON or OFF respectively. If any of the RXT-300s in the network do not enter RF silence, the HMI panel will display the message:

```

NOT ALL RXT-300S ENTERED RF SILENCE,
DO YOU WANT TO CONTINUE?

```

```

YES NO VIEW

```

Selecting YES will proceed with implementing RF silence for the selected RXTs. Selecting NO will cancel the RF silence function. Selecting VIEW will display all the RXT-300s in the network by their MAC address and their corresponding RF silence status. NORMAL indicates RXTs that are not in RF silence and RF SIL indicates RXTs that are in RF silence. In RF silence, the sensors are not monitored and no alarms can be activated.

The INHIBIT TIMERS mode is used to momentarily disable alarms in the system when calibrating sensors to prevent the alarms from firing. It has a timer range from 0-60 minutes. Once the timer value has been entered in minutes and seconds, select START and all relay outputs on the network will be disabled until the timer reaches 0 or is manually stopped by the user.

### 5.3.4 Alarm Test Mode

The ALARM TEST MODE menu allows the user to simulate alarm conditions and verify relay contacts. Upon entering this menu, the LCD will display:

```

ALARM TEST MODE

```

```

OFF

```

A swipe over the ENTER marker will toggle the alarm test mode ON or OFF. When turned ON, the alarm test mode simulates alarm conditions by incrementing all active device readings from 0 - 100% of the range in 5% increments. When full scale is reached, the readings will decrement back to 0 and the unit will exit the test mode. The test mode can also be terminated at any time during the test cycle by turning OFF the alarm test mode. As the readings cross their respective alarm set points, the relays will fire according to their configuration.

### 5.3.5 System Diagnostics

The SYSTEM DIAGNOSTICS menu performs function tests for the LCD display, the panel LED’s and the external reset switch, if one has been installed. Upon entering this menu, the HMI panel will automatically initiate a function test that displays every pixel of the 4 line, 40 character LCD display. The unit then performs a function test of the LED drivers by activating all four LED’s. After the LED test, the unit will initiate a test for the external reset switch which lets the user know when the reset switch is pressed. The user will be prompted to “PRESS ENTER KEY TO CONTINUE” meaning a swipe of the ENTER marker.

This will end the system diagnostics test and the display will revert back to the SYSTEM DIAGNOSTICS menu.

### 5.3.6 Display Settings

The DISPLAY SETTINGS menu allows the user to customize the brightness, contrast and backlight duration of the display. Upon entering this menu, the LCD will display:

#### DISPLAY SETTINGS

BRIGHTNESS: ###      BACKLIGHT OFF: ##:##  
CONTRAST: ###

These values can be changed by swiping the magnet over the markers of the up or down arrows to move the arrow prompt “→” to the desired function. A swipe over the ENTER marker will select the function indicated by the arrow prompt “→” and the value can be changed by swiping over the markers of the up or down arrows. Another swipe over the ENTER marker will save the selected value. Values for brightness can range between 0 and 100 in increments of 10. Values for contrast can range between 30 and 100 in increments of 10. Available values for the backlight timeout function are OFF, 10 seconds, 30 seconds and 1-5 minutes. The backlight timeout is the amount of time the user has before the LCD backlight will turn off while in the Main Display due to inactivity.

### 5.3.7 About System

The ABOUT SYSTEM menu displays system information such as the HMI firmware version, the HMI hardware version, the microcontroller firmware version and the RXT-300 firmware version and device image. Upon entering this menu, the LCD will display:

DETCON INC  
SMART WIRELESS HMI PANEL  
VERSION #.##

Swipe the magnet over the marker of the down arrow to display the hardware information. Perform another swipe to display the microcontroller information. Perform a final swipe to display the RXT-300 information. By swiping the magnet over the marker of the up arrow, the display will revert to the previous screen.

## 6.0 Warranty

Detcon, Inc., as the manufacturer, warrants under intended normal use each new SmartWireless™ HMI panel to be free from defects in material and workmanship for a period of one year from the date of shipment to the original purchaser. Should the controller fail to perform in accordance with published specifications within the warranty period, return to Detcon, Inc., for necessary repairs or replacement. All warranties and service policies are FOB the Detcon facility located in The Woodlands, Texas.

## 7.0 Specifications

### **Capacity**

32 Input Devices

### **Power Input**

N4X Input Voltage: 100-240VAC, 45-65Hz  
11.5-30VDC  
N7 Input Voltage: 11.5-30VDC

### **Power Consumption**

Nominal: .07 Watt @ 11.5VDC  
Maximum: 1.2 Watts @ 11.5VDC (Includes Display w/Backlight and 4 LED's active)

### **Display**

1 $\frac{1}{4}$ " x 6" Backlit LCD

### **RFI/EMI Protection**

Complies with EN61326

### **Electrical Classification**

NEMA 4X or NEMA 7

### **Dimensions**

N4X Dimensions: 11.85"W x 13.73"H x 6.47"D  
N7 Dimensions: 25"W x 15.5"H x 7.25"D (Full Assembly w/Mounting Plate)

### **Operating Temperature Range**

-20°C to +70°C

### **Warranty**

One year

## 8.0 Spare Parts

Part Number	Spare Parts
957-827280-032	SmartWireless HMI Panel in NEMA 7
327-000000-000	Programming Magnet
800-003648-000	Mounting Plate
976-000300-316	RXT-300 Wireless Transceiver
500-005143-100	Terminal Board
897-850902-010	NEMA 7 Tall Aluminum Condulet w/Window Cover
976-000303-012	12V Smart Battery Pack
960-202200-000	Condensation prevention packet (For condulet, replace annually)
897-044400-34T	$\frac{3}{4}$ " NPT T-Outlet Box w/Aluminum Cover
8522-750	$\frac{3}{4}$ " NPT Plug
898-52310	$\frac{1}{2}$ " NPT Drain
899-07550	$\frac{3}{4}$ " NPT to $\frac{1}{2}$ " NPT Adapter
899-15075	$\frac{3}{4}$ " NPT x 1.5" Nipple
301-58205	$\frac{3}{4}$ " NPT Cord Connector
Part Number	Optional Accessories
976-000304-004	Quad Charger w/AC Adapter
976-0003FF-000	RXT Wireless Configuration Tool

## 9.0 Revision Log

Revision	Date	Changes made	Approval
0.0	10/12/2011	Initial Release.	LU
1.0	03/27/2012	Added N4X enclosure option (For RSM).	LU