

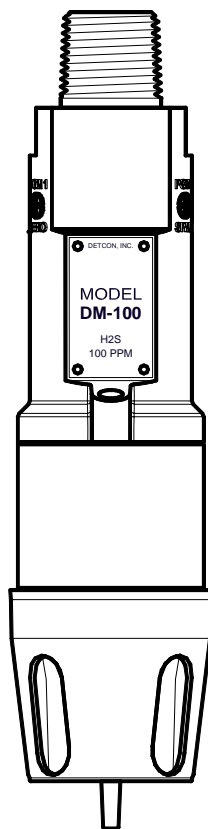

Model DM-100

DM-100 Toxic Gas Sensors
DM-100 O2 Deficiency Sensors



Operator's Installation and Instruction Manual

Covers all Model DM-100 Sensors

◆ DETCON, Inc.
3200 Research Forest Dr.,
The Woodlands, Texas 77387
Ph.281.367.4100 / Fax 281.298.2868
www.detcon.com

This page left intentionally blank

Table of Contents

1.	Introduction	1
1.1	Description	1
1.2	Modular Mechanical Design	2
1.3	Model 100 Standard Terminal Board (Optional)	3
1.4	Model 100 Display Terminal Board (Optional)	4
1.5	Model 100 Series Display (Optional)	5
1.6	Wireless Transceiver and Battery Pack (Optional)	5
2.	Installation	6
2.1	Hazardous Locations Installation Guidelines for Safe Use	6
2.2	Sensor Placement	7
2.3	Sensor Contaminants and Interference	8
2.4	Sensor Mounting	8
2.5	Electrical Installation	9
2.6	Field Wiring	10
2.6.1	Model 100 Display Terminal Board Settings	11
2.7	Initial Start Up	12
2.7.1	Toxic Gas Sensors	12
2.7.2	O ₂ Deficiency Sensors	13
3.	Operation	15
3.1	Normal Operation	15
3.2	Calibration	16
3.2.1	Zero Calibration	16
3.2.2	Span Calibration	17
3.3	Fault Diagnostic/Failsafe Feature	18
4.	Service and Maintenance	19
4.1	Replacement of Plug-in Sensor	19
4.2	Replacement of ITM	19
4.3	Replacement of the Model 100 Terminal Board	20
5.	Troubleshooting Guide	22
6.	Customer Support and Service Policy	24
7.	DM-100 Sensor Warranty	25
8.	Appendix	26
8.1	Specifications	26
8.2	Sensor Specific Data	27
8.3	Interference Table	29
8.4	Spare Parts, Sensor Accessories, Calibration Equipment	35
8.5	Revision Log	36

Table of Figures

Figure 1 Sensor Assembly with Optional J-Box and LED Display	1
Figure 2 Construction of Electrochemical Toxic Sensor.....	1
Figure 3 Construction of Galvanic Cell.....	2
Figure 4 Sensor Assembly Breakaway.....	2
Figure 5 Functional Block Diagram.....	3
Figure 6 Plug-in Sensor.....	3
Figure 7 Standard Terminal Board.....	4
Figure 8 Model 100 Display Terminal Board	4
Figure 9 Model 100 Series Display.....	5
Figure 10 Approval Label	6
Figure 11 Typical DM-100 Sensor Assembly and Mounting Dimensions	9
Figure 12 Typical Installation	10
Figure 12 Magnetic Programming Tool.....	15
Figure 13 Magnetic Programming Switches.....	15

List of Tables

Table 1 Wire Gauge vs. Distance.....	10
Table 2 Model 100 Terminal Board Jumper	11
Table 4 Sensor Specific Data	27
Table 5 Interfering Gases	29
Table 6 Cross Interference Table	30

Shipping Address: 3200 A-1 Research Forest Dr., The Woodlands Texas 77381

Mailing Address: P.O. Box 8067, The Woodlands Texas 77387-8067

Phone: 888.367.4286, 281.367.4100 • Fax: 281.292.2860 • www.detcon.com • sales@detcon.com

1. Introduction

1.1 Description

Detcon Model DM-100 toxic gas and O₂ deficiency sensors are non-intrusive 4-20mA loop powered sensors designed to detect and monitor a wide range of toxic gases in air. Ranges of detection for toxic gases are from 0-1ppm up to 0-10,000ppm; typical ranges of detection are 0-10ppm, 0-25ppm, 0-50ppm and 0-100ppm. Ranges for O₂ deficiency are 0-1% up to 0-25% by volume. The basic sensor assembly consists of an electrochemical fuel cell mounted in Intrinsically Safe stainless steel housing and includes a Splash Guard Cal Adapter. Optionally, the sensor can be installed on an explosion proof junction box with a Model 100 Terminal Board and may include a Model 100 Loop Powered LED Display. Other options are available, contact Detcon for more information.

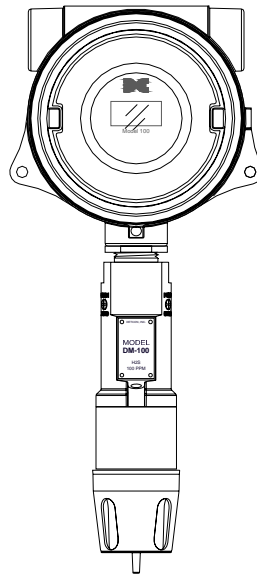

Figure 1 Sensor Assembly with Optional J-Box and LED Display

Electrochemical Sensor Technology

The Toxic gas sensors are based on electrochemical cells. Each cell consists of three electrodes embedded in an electrolyte solution all housed beneath a diffusion membrane. Sensitivity to specific target gases is achieved by varying composition of any combination of the sensor components. Good specificity is achieved in each sensor type. The cells are diffusion limited via small capillary barriers resulting in a long service life of up to three or more years. The electrochemical cell is packaged as a field replaceable plug-in sensor.

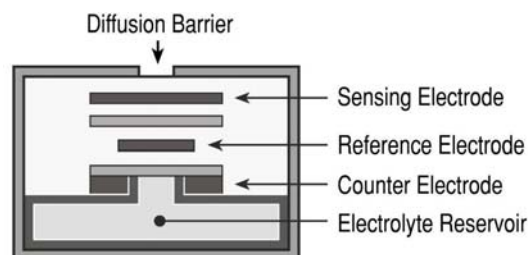

Figure 2 Construction of Electrochemical Toxic Sensor

The O₂ deficiency sensor technology is a two electrode galvanic metal air battery type cell, which is housed as a field replaceable intelligent plug-in sensor. The cell is diffusion limited and functions as a direct current

generator proportional to the amount of oxygen adsorption. The sensors are temperature compensated and show good accuracy and stability over the operating temperature range of -20° to 50°C (-4° to $+122^{\circ}$ Fahrenheit). The sensor is warranted for two years and has an expected service life of up to 2.5 years in ambient air at 20.9% oxygen.

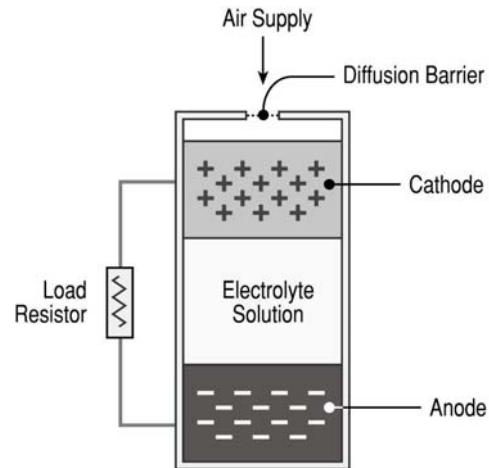

Figure 3 Construction of Galvanic Cell

1.2 Modular Mechanical Design

The Model DM-100 Sensor Assembly is completely modular and is made up of four parts (See Figure 4 for Assembly Breakaway):

- 1) DM-100 Intelligent Transmitter Module (ITM)
- 2) Intelligent Plug-in Sensor (varies by gas type and range)
- 3) 100 Series Bottom Housing Assembly (H₂S assemblies use 100 Series Bottom Housing Assembly with Integral Filter)
- 4) Splash Guard.

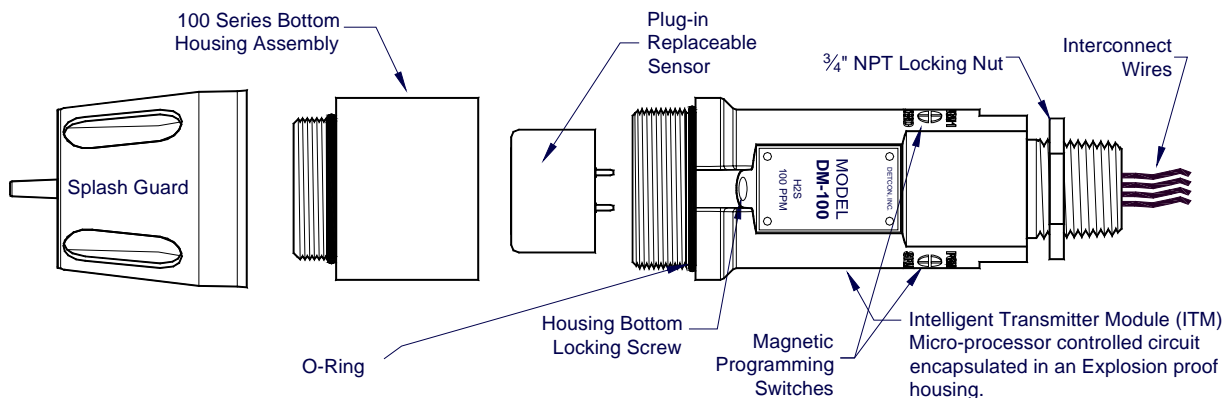

Figure 4 Sensor Assembly Breakaway

NOTE: All metal components are constructed from electro polished 316 Stainless Steel in order to maximize corrosion resistance in harsh environments.

DM-100 Intelligent Transmitter Module

The Transmitter Module is a microprocessor-based package that is attached to the explosion proof junction box. Circuit functions include an Intrinsically safe barrier, on-board power supply, microprocessor, magnetic

programming switches, and a linear 4-20mA DC output. Magnetic program switches located on either side of the ITM are activated via a hand-held magnetic programming tool, thus allowing non-intrusive operator interface with the Transmitter Module. Electrical classifications are Class I, Division 1, Groups A, B, C, and D.

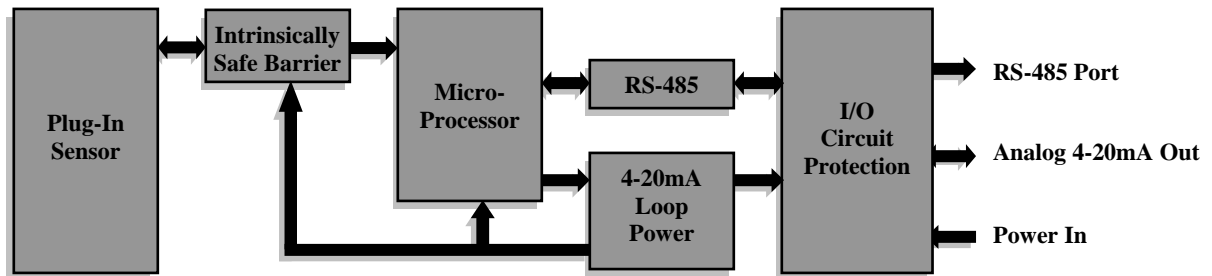

Figure 5 Functional Block Diagram

Field Replaceable Sensor

The Detcon family of electrochemical gas sensors is field proven, plug-in sensors with over-sized gold-plated connections that eliminate corrosion problems. The sensor can be accessed and replaced in the field easily by releasing the locking screw and unthreading the Splash Guard Adapter. Detcon's family of toxic sensors has a long shelf life and is supported by an industry-leading warranty.



Figure 6 Plug-in Sensor

1.3 Model 100 Standard Terminal Board (Optional)

If the sensor is ordered with an explosion proof conduit/junction box, the sensor will come with the Model 100 Standard Terminal Board mounted in the J-Box (see Figure 7). This terminal board affords the user easy plug in connectors for use in wiring the unit during installation, and convenient test points for measuring the milliamp (mA) output.

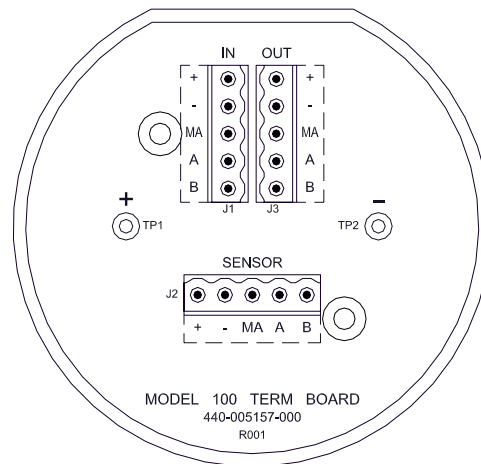

Figure 7 Standard Terminal Board

This terminal board provides an easy Digital Volt Meter (DVM) connection for reading the mA output from the sensor. Two test points (TP1 and TP2) provide a connection across a 10Ω resistor that develops a 10mV voltage drop per 1mA output. Thus a reading of 40mV on a DVM equals 4mA of current. This is an alternative method to reading the mA output of the sensor for assemblies that do not include the 100 Series Display option. Refer to section 2.6 Field Wiring for more information about the setup of the Model 100 Terminal Board.

1.4 Model 100 Display Terminal Board (Optional)

If the unit is ordered with the optional display or a battery pack (as used in wireless configurations) the unit comes with the Model 100 Display Terminal Board mounted in the J-Box (See Figure 8).

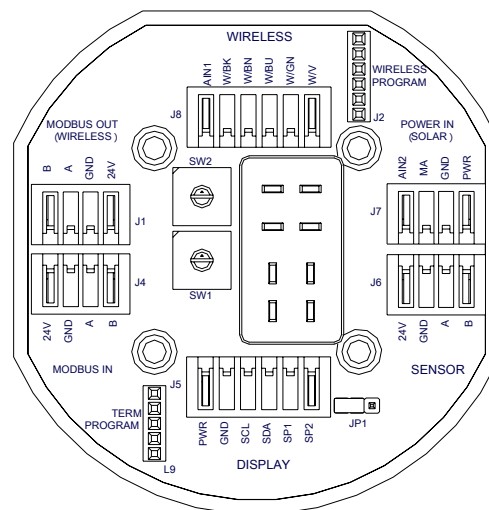

Figure 8 Model 100 Display Terminal Board

This terminal board includes connectors for the following:

- J1 4-Pin Connector – Modbus Out (Wireless Transceiver Option)
- J2 6-Pin Header – Wireless Transceiver Programming Header
- J3 6-Pin Connector – used for battery operation or display interface dependant on sensor configuration
- J4 4-Pin Connector – Modbus In
- J5 6-Pin Connector – used for Display interface with battery/wireless configurations

- J6 4-Pin Connector – Sensor connections
- J7 4-Pin Connector – Auxiliary power in and mA out.
- J8 6-Pin Connector – Wireless Transceiver
- J9 5-Pin Header – Terminal Board Programming

The Model 100 Display Terminal Board does not provide test points for measuring the milliamp (mA) output. The mA output is available at J7.

1.5 Model 100 Series Display (Optional)

The Model 100 Series Display is a 4-digit LED display that provides a direct display of the sensor readings. In units that are ordered with the optional display, the display is mounted directly onto the J3 Beau connector of the Display Terminal Board so the display can be easily seen through the J-box window. The display automatically identifies the ITM, the sensor type, and range. This factory installed option must be ordered along with the sensor assembly.



Figure 9 Model 100 Series Display

1.6 Wireless Transceiver and Battery Pack (Optional)

The DM-100 has the option to operate on a wireless network with the addition of a wireless transceiver and battery pack. These options allow the sensor to be remotely mounted without the need for any cables. These options are factory installed. Contact Detcon for more information on these options.

2. Installation

2.1 Hazardous Locations Installation Guidelines for Safe Use

1. Install sensor only in areas with classifications matching with those described on the approval label. Follow all warnings listed on the label.

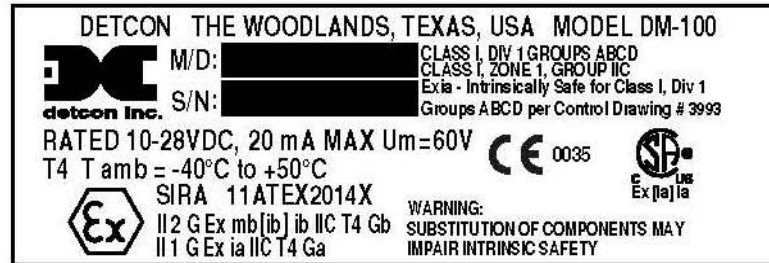

Figure 10 Approval Label

2. For intrinsically safe Ex ia installations, follow the intrinsically safe installation guidelines shown in control drawing #3993.
3. For non-intrinsically safe Ex mb [ib] installations, ensure that the sensor is properly threaded into a suitable explosion-proof rated junction box with a downward pointing female 3/4" NPT threaded connection. The sensor should be threaded up at least 5 full turns until tight, with the LED display facing forward. Avoid use of Teflon Tape, or any type of non-conductive pipe thread coating on the NPT threaded connection.
4. A good ground connection should be verified between the sensor's metal enclosure and the junction box. If a good ground connection is not made, the sensor can be grounded to the junction box using the sensor's external ground lug. Also verify a good ground connection between the junction box and earth ground.
5. Proper precautions should be taken during installation and maintenance to avoid the build-up of static charge on the plastic components of the sensor. These include the Splash Guard and Splash Guard adapter.
6. All input circuits of the DM-100 must be connected to current limiting devices (e.g. Fuses of 1500 amp breaking capacity) to ensure that the maximum input current does not exceed 62ma.
7. Do not substitute components. Substitution of components may impair the intrinsic safety rating.
8. Do not operate the sensor outside of the stated operating temperature limits.
9. Do not operate the sensor outside the stated operating limits for voltage supply.
10. These sensors meet ATEX standards EN60079-0, EN60079-18 and EN60079-11.
11. These sensors have a maximum safe location voltage of Um=60V.
12. These sensors pass dielectric strength of 500VRMS between circuit and enclosure for a minimum of 1 minute at a maximum test current of 5mA.

13. The DM-100 may be used as an oxygen deficiency sensor; the DM-100 must not be used for detecting oxygen concentrations expected to be greater than 21%.
14. The DM-100 must only use gas sensor cell models 371-xxxxxx-xxx as detailed within table 4 of section 8.1. No other gas sensor cells shall be used.

2.2 Sensor Placement

Selection of sensor location is critical to the overall safe performance of the product. Five factors play an important role in selection of sensor locations:

- (1) Density of the gas to be detected
- (2) Most probable leak sources within the industrial process
- (3) Ventilation or prevailing wind conditions
- (4) Personnel exposure
- (5) Maintenance access

Density

Placement of sensors relative to the density of the target gas is such that sensors for the detection of heavier than air gases should be located within 4 feet of grade as these heavy gases will tend to settle in low lying areas. For gases lighter than air, sensor placement should be 4-8 feet above grade in open areas or in pitched areas of enclosed spaces.

Leak Sources

The most probable leak sources within an industrial process include flanges, valves, and tubing connections of the sealed type where seals may either fail or wear. Other leak sources are best determined by facility engineers with experience in similar processes.

Ventilation

Normal ventilation or prevailing wind conditions can dictate efficient location of gas sensors in a manner where the migration of gas clouds is quickly detected.

Personnel Exposure

The undetected migration of gas clouds should not be allowed to approach concentrated personnel areas such as control rooms, maintenance or warehouse buildings. A more general and applicable thought toward selecting sensor location is combining leak source and perimeter protection in the best possible configuration.

Maintenance Access

Consideration should be given to providing easy access for maintenance personnel. Consideration should also be given to the consequences of close proximity to contaminants that may foul the sensor prematurely.

NOTE: In all installations the gas sensor should point straight down (refer to Figure 12). Improper sensor orientation may result in false readings and permanent sensor damage.

Additional Placement Considerations

The sensor should not be positioned where it may be sprayed or coated with surface contaminating substances. Painting sensor assemblies is prohibited.

Although the sensor is designed to be RFI resistant, it should not be mounted in close proximity to high-powered radio transmitters or similar RFI generating equipment.

When possible mount in an area void of high wind, accumulating dust, rain, or splashing from hose spray, direct steam releases, and continuous vibration. If the sensor cannot be mounted away from these conditions then make sure the Detcon Harsh Location Dust Guard accessory is used.

Do not mount in locations where temperatures will exceed the operating temperature limits of the sensor. Where direct sunlight leads to exceeding the high temperature-operating limit, use a sunshade to help reduce temperature.

2.3 Sensor Contaminants and Interference

Electrochemical toxic gas may be adversely affected by exposure to other airborne gases. Depending on the cross-sensitivity relationship, there may be a positive or negative impact on the reading.

The most commonly present gases that potentially cause interference problems are listed in Table 4 Interfering Gases and Table 5 Cross Interference Table (Refer to section 8.3 Interference Table).

The presence of cross-interference gases in an area does not preclude the use of this sensor technology, although it is possible that the sensor could experience a false high or false low reading should exposure occur.

Cross-Interference Data Table

Table 5 Cross Interference Table (refer to Section 8.3 Interference Table) lists the gases typically found in industrial environments that may cause a cross-interference response on members of the Detcon family of toxic gas sensors. Review Table 5 in Section 8.3 for the correct gas and then scan across the list for possible interference gases. Determine the magnitude of cross-interference that may occur.

2.4 Sensor Mounting

The DM-100 should be vertically oriented so that the sensor points straight downward. The explosion-proof enclosure or junction box is typically mounted on a wall or pole (See Figure 11). Detcon provides a selection of standard junction boxes in both Aluminum and Stainless Steel.

NOTE: If wall mounting without a mounting plate, make sure to use at least 0.5" spacers underneath the J-Box's 1/4" mounting holes to move the wireless sensor assembly away from the wall and allow access clearance to the sensor assembly.

NOTE: Do not use Teflon Tape or any other type of Pipe Thread material on the 3/4" threads unless the sensor is mounted in a severe or harsh environment. Metal-on-metal contact must be maintained to provide a solid electrical ground path. If Teflon Tape is used the Sensor *must* be externally grounded using a ground strap.

When mounting on a pole, secure the Junction Box to a suitable mounting plate and attach the mounting plate to the pole using U-Bolts. (Pole-Mounting brackets for Detcon Junction Box's are available separately.)

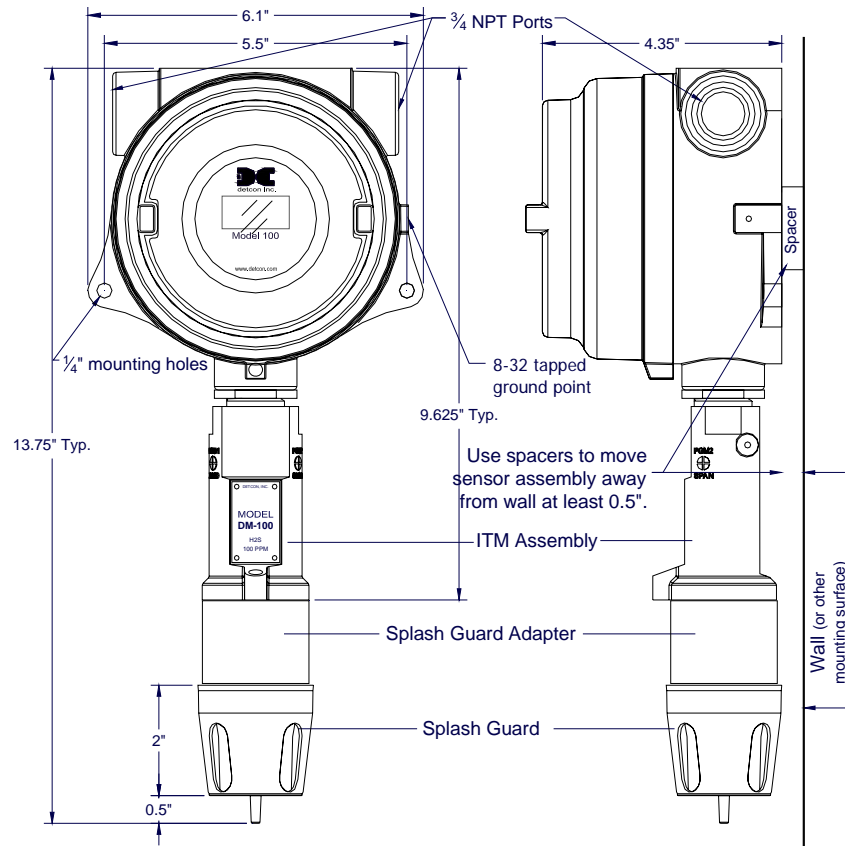

Figure 11 Typical DM-100 Sensor Assembly and Mounting Dimensions

2.5 Electrical Installation

The Sensor Assembly should be installed in accordance with local electrical codes. The sensor assemblies are CSA/NRTL approved (US and Canada) for Class I, Division 1, Groups A, B, C, & D area classifications, and are ATEX Approved for Class I, Zone 1, Group IIC area classifications.

Proper electrical installation of the gas sensor is critical for conformance to Electrical Codes and to avoid damage due to water leakage. Refer to Figure 8 and Figure 12 for proper electrical installation.

NOTE: If a conduit run exits the secondary port, repeat the installation technique shown in Figure 12.

In Figure 12, the drain allows H₂O condensation inside the conduit run to safely drain away from the sensor assembly. The electrical seal fitting is required to meet the National Electrical Code per NEC Article 500-3d (or Canadian Electrical Code Handbook Part 1 Section 18-154). Requirements for locations of electrical seals are covered under NEC Article 501-5. Electrical seals also act as a secondary seal to prevent water from entering the wiring terminal enclosure. However, they are not designed to provide an absolute watertight seal, especially when used in the vertical orientation.

NOTE: A conduit seal is typically required to be located within 18" of the J-Box and Sensor Assembly. Crouse Hinds type EYS2, EYD2 or equivalent are suitable for this purpose.

NOTE: The Detcon Warranty does not cover water damage resulting from water leaking into the enclosure.

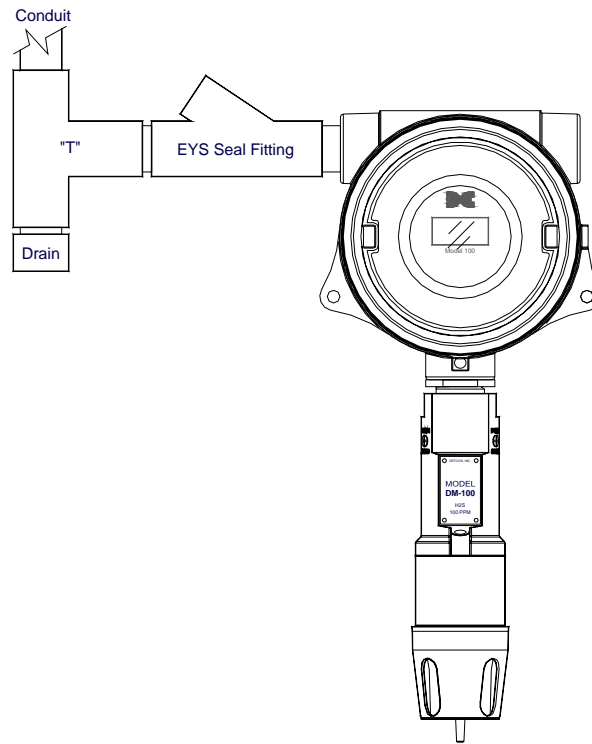

Figure 12 Typical Installation

NOTE: Any unused ports should be blocked with suitable 3/4" male NPT plugs. Detcon supplies one 3/4" NPT male plug with each J-box enclosure. If connections are other than 3/4" NPT, use an appropriate male plug of like construction material.

2.6 Field Wiring

Detcon Model DM-100 sensor assemblies require two conductor connections between power supplies and host electronic controller's 4-20mA input. Wiring designations are '+' and 'mA' (sensor signal). The maximum wire length between sensor and 24VDC source is shown in the Table below. The maximum wire size for termination in the Junction Box is 14 AWG.

Table 1 Wire Gauge vs. Distance

AWG	Wire Dia.	Meters	Feet	Over-Current Protection
22	0.723mm	700	2080	3A
20	0.812mm	1120	3350	5A
18	1.024mm	1750	5250	7A
16	1.291mm	2800	8400	10A
14	1.628mm	4480	13,440	20A

NOTE 1: Wiring table is based on stranded tinned copper wire and is designed to serve as a reference only.

NOTE 2: Shielded cable is required for installations where cable trays or conduit runs include high voltage lines or other possible sources of induced interference. Separate conduit runs are highly recommended in these cases.

NOTE 3: The supply of power should be from an isolated source with over-current protection as stipulated in table.

Terminal Connections – with Junction Box Option



CAUTION: Do not apply System power to the sensor until all wiring is properly terminated. Refer to Section 2.7 Initial Start Up

1. Remove the junction box cover.
2. If the sensor has the LED Display option installed, unplug the display from the terminal board by pulling the display out of the junction box. The display option plugs directly into the terminal board’s Beau Connector.
3. Observing correct polarity, terminate the 3-conductor power and 4-20mA field wiring (‘+’ ‘-’ and ‘mA’) at the terminal board connector J1 (4-20mA Out) on the Standard Terminal Board shown in Figure 7, or J7 (PWR GND and MA) on the Display Terminal Board shown in Figure 8.
4. Trim and cap all exposed wire leads if they are not permanently landed in the terminal board.
5. The sensor should be connected to J2, labeled “SENSOR” on the Standard Terminal Board, and J6, labeled “SENSOR”, on the Display Terminal Board. On the Standard Terminal Board, the wiring from the sensor should match the silkscreen on the terminal board: R–Red, BK–Black, GN–Green, BU–Blue, and W–White. On the Display Terminal Board the wiring should be: Red-PWR, Black-GND, White-A, Blue-B (Green is not connected).
6. On the Display Terminal Board other connectors are provided for factory installed options. The options ordered will dictate if, and what connectors are used. The display option is plugged into the Beau connector (J3) for a DM-100 with just the display option added. Other options are covered in the associated manual for those options.
7. If a display was removed in step 2, re-install the display by plugging it back into the terminal board.
8. Replace the junction box cover after Initial Start Up.

NOTE: A 6-32 or 8-32 threaded exterior ground point is provided on most junction boxes for an external ground. If the Sensor Assembly is not mechanically grounded, an external ground strap *must* be used to ensure that the sensor is electrically grounded.

2.6.1 Model 100 Display Terminal Board Settings

The Model 100 Display Terminal Board contains a jumper that must be configured properly for the board to operate properly. The jumper is normally configured at the factory and should not be changed. Misplacement of the jumper may cause the sensor to become inoperative.

Table 2 Model 100 Terminal Board Jumper

JP1	1-2 – Battery installed	2-3 – Display only
-----	-------------------------	--------------------

2.7 Initial Start Up

2.7.1 Toxic Gas Sensors

Upon completion of all mechanical mounting and termination of all field wiring, apply system power in the range of 11-26VDC (24VDC typical) and observe the following normal conditions:

1. If the Loop Powered Display option is installed, the display should read 0.0 upon power up. If a Loop Powered Display is not installed on the sensor, set a DVM to measure millivolts, and connect it across TP1 and TP2 on the terminal board. The DVM will read the voltage drop across a 10 Ω resistor. The resistor develops a 10mV voltage drop per 1mA of current. Thus a reading of 40mV on a DVM equals 4mA of current.
2. A temporary upscale reading may occur as the sensor stabilizes. This upscale reading will decrease to "0" ppm (40mV on the DVM) within 1-2 minutes of power-up, assuming there is no gas in the area of the sensor.

NOTE: The 4-20mA signal is held constant at 4mA for the first two minutes after power up.

3. Sensors cells that use a bias voltage require a longer time to stabilize. This can vary between 1 and 24 hours depending on the sensor type and range. Biased sensors include NH₃, NO, HCl, and VOC gases (ethylene oxide, ethylene, methanol, formaldehyde....etc).

Initial Operational Tests

After a warm up period of 1 hour (or when zero has stabilized), the sensor should be checked to verify sensitivity to the target gas.

Material Requirements

- Detcon PN 613-120000-700 Splash Guard with integral Cal Port with Wind Guard -OR-
- Detcon PN 943-000006-132 Threaded Calibration Adapter - OR -
- Detcon P/N 943-01747-T05 Teflon Calibration Adapter for highly reactive gases
- Detcon Span Gas; 50% of range target gas in balance N₂ or Air at fixed flow rate between 200-500cc/min (500cc/min is preferred)
- DVM (if a loop powered display is not installed)

NOTE: Calibration gas generators using perm tubes or electrochemical sources may be used in place of span gas cylinders.

NOTE: The cover of the junction box will need to be removed if there is not a loop powered display. The area may need to be de-classified.

1. If the sensor has a loop power display installed, the display should read "0". If a DVM is used to measure the 4-20mA output, set the DVM to measure millivolts and connect the leads across TP1 and TP2 on the terminal board. The DVM should read 40 \pm 2mV.
2. Attach the calibration adapter to the Splash Guard adapter or connect tubing to integral cal port. It is recommended that the Wind Guard (Detcon P/N 943-000000-000) in installed over the Splash Guard during calibration. Apply the test gas at a controlled flow rate of 200 - 500cc/min (500cc/min is the recommended flow). If the sensor has a loop power display attached the reading should increase to 50% of full range (if the range is 100, the display should read 50). Observe that the DVM increases to

a level near that of the applied calibration gas value. Typically this would be 50% of full range, a reading of $120 \pm 2 \text{mV}$ (12mA)

3. Remove test gas and observe that, if the sensor has a loop power display installed, the display decreases to “0”. If a DVM is used the DVM reading should decrease back to 40mV (4mA).
4. If a calibration adapter was used during these tests, remove them from the unit, and re-install the Splash Guard. If the wind guard was used, remove the wind guard.

Initial operational tests are complete. DM-100 toxic gas sensors are factory calibrated prior to shipment, and should not require significant adjustment on start up. However, it is recommended that a complete calibration test and adjustment be performed 16 to 24 hours after power-up. Refer to zero and span calibration instructions in Section 3.2 Calibration.

2.7.2 O₂ Deficiency Sensors

Upon completion of all mechanical mounting and termination of all field wiring, apply system power in the range of 11-30VDC (24VDC typical) and observe the following normal conditions:

If the sensor has a loop power display installed, the display should read close to 20.9%. If a DVM is used to measure the 4-20mA output, set the DVM to measure millivolts and connect the leads across TP1 and TP2 on the terminal board. The DVM should read $73.4 \pm 2 \text{mV}$.

The reading should stabilize within 1 to 2 minutes of power-up (assuming a ‘normal’ ambient O₂ concentration).

Initial Operational Tests

After a warm-up period of 5 minutes the sensor should be checked to verify response to O₂ deficiency.

Material Requirements

- Detcon PN 613-120000-700 Splash Guard with integral Cal Port with Wind Guard -OR-
- Detcon PN 943-000006-132 Threaded Calibration Adapter - OR -
- Detcon P/N 943-01747-T05 Teflon Calibration Adapter for highly reactive gases
- Detcon Zero Gas: 100% N₂ at fixed flow rate of 200-500cc/min
- DVM (if a loop powered display is not installed)

NOTE: The cover of the junction box will need to be removed if there is not a loop powered display. The area may need to be de-classified.

1. Attach the calibration adapter to the threaded sensor housing or connect tubing to the integral cal port. Apply the test gas at a controlled flow rate of 200-500cc/min (500cc/min is the recommended flow).
2. If the sensor has a loop power display installed, the display reading should drop to “0”. If a DVM is used to measure the 4-20mA output, set the DVM to measure millivolts and connect the leads across TP1 and TP2 on the terminal board. The DVM should read $40 \pm 2 \text{mV}$.
3. Remove test gas and calibration adapter. If the sensor has a loop power display installed, the display should return to a reading of 20.9%. The DVM should return to a reading of 173.7mV (17.37mA).

Initial operational tests are complete. DM-100 O₂ deficiency sensors are factory calibrated prior to shipment, and should not require significant adjustment on start up. However, it is recommended that a complete calibration test and adjustment be performed 16 to 24 hours after power-up. Refer to zero and span calibration instructions in Section 3.2 Calibration.

3. Operation

The Operator Interface of the Model 100 Series gas sensors is accomplished via two internal magnetic switches located on the left and the right of the sensor (Figure 14). The two switches, labeled “PGM1” and “PGM2”, allow for complete calibration of the sensor. The addition of the Loop Powered Display allows the ability to calibrate the sensor without the need to de-classify the area or the use of hot permits.



Figure 13 Magnetic Programming Tool

The magnetic programming tool (Figure 13) is used to operate the magnetic switches. Switch action is defined as momentary contact and 3-second hold. Hold time is defined as the time from the point when the magnet is placed in close proximity with the switch. For momentary contact the programming magnet is briefly held over a switch location. The location of “PGM1” and “PGM2” are shown in Figure 14.

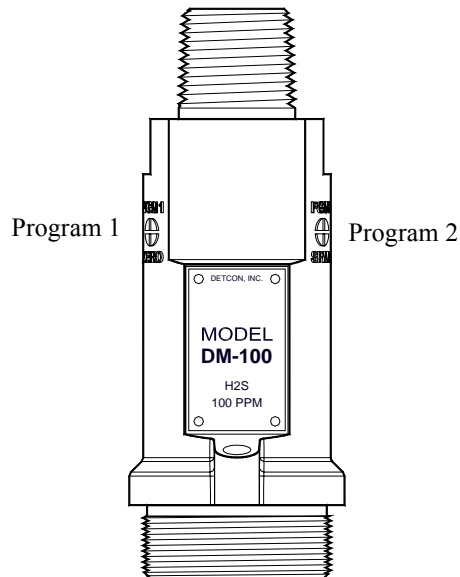

Figure 14 Magnetic Programming Switches

3.1 Normal Operation

In normal operation, the mA output will be the current sensor reading. In normal operation, the 4-20mA current output linearity corresponds with the full-scale range. If the 100 Series Display option is added to the sensor, the display continuously shows the current sensor reading in ppm or % by volume, which will normally appear as “0”. If the sensor is actively experiencing any diagnostic faults, the mA output will be taken to 1.2mA to designate a fault to the controller. The 100 Series Display will display an error code to signify a fault. Error codes are noted by Fxx, where F is Fault and xx is an error code. Error codes are defined in section 5 Troubleshooting Guide .

3.2 Calibration

Zero and span calibration should be performed on a routine basis (quarterly minimum) to ensure reliable performance. If a sensor has been exposed to any de-sensitizing gases, or to very high over-range combustible gas levels, re-calibration should be considered. Unless otherwise specified, span adjustment is recommended at 50% of the full scale range.

3.2.1 Zero Calibration

The zero calibration is used to zero the sensor. Zero calibration should be performed periodically or as required. Zero calibration should be considered after periods of over-range target gas exposure. Local ambient air can be used to zero calibrate a toxic gas sensor as long as it can be confirmed that it contains no target or interference gases. If this cannot be confirmed then a zero air or N₂ cylinder should be used. Pure N₂ must be used for zero calibration of the O₂ deficiency sensors.

Material Requirements:

- Detcon PN 327-000000-000 Programming Magnet
- Detcon PN 613-120000-700 Splash Guard with integral Cal Port with Wind Guard -OR-
 - Detcon PN 943-000006-132 Threaded Calibration Adapter - OR -
 - Detcon P/N 943-01747-T05 Teflon Calibration Adapter for highly reactive gases
- Detcon PN 942-001123-000 Zero Air cal gas (or use ambient air if no target gas is present).
- Detcon P/N 942-640023-100 Nitrogen 99.99%
- DVM (if a loop powered display is not installed)

NOTE: The zero gas source may be zero air or N₂ for toxic sensors, but must be pure N₂ (99.99%) for O₂ deficiency sensors

NOTE: The cover of the junction box will need to be removed if there is not a loop powered display. The area may need to be de-classified.

1. If a 100 Series Display is *not* installed on the sensor, set a DVM to measure millivolts, and connect it across TP1 and TP2 on the terminal board. The DVM will read the voltage drop across a 10Ω resistor. The resistor develops a 10mV voltage drop per 1mA of current. Thus a reading of 40mV on a DVM equals 4mA of current.
2. For toxic sensors, if the ambient air is known to contain no target gas content, then it can be used for zero calibration. If a zero gas cal cylinder is going to be used, attach the calibration adapter and set flow rate of 200-500cc/min (500cc/min is the recommended flow rate) and let sensor purge for 1-2 minutes before zeroing the sensor. For O₂ deficiency sensors, apply N₂ at a set flow rate of 500cc/min for 3-5 minutes before zeroing the sensor.
3. From Normal Operation, hold the programming magnet over PGM1 for 3 seconds. The display (if connected) will flash “CAL” three times and then should display ‘0.0’ and will flash at a rate of once per second. If a meter is attached, the reading will dip momentarily to 2mA (20mV on the meter). The reading will then return to 4ma. (The ideal reading for zero is 4.03mA or 40.3mV.)
4. Observe the reading for a minute or so to ensure that the reading does not drift.
5. If zero gas was used, remove the gas from the sensor.

3.2.2 Span Calibration

Span Calibration is used to adjust the span of the sensor. Span calibration should be performed periodically or as required. Span calibration should be considered after periods of over-range target gas exposure. Unless otherwise specified, span adjustment is recommended at 50% of range.

Material Requirements:

- Detcon PN 327-000000-000 Programming Magnet
- Detcon PN 613-120000-700 Splash Guard with integral Cal Port with Wind Guard -OR-
 - Detcon PN 943-000006-132 Threaded Calibration Adapter - OR -
 - Detcon P/N 943-01747-T05 Teflon Calibration Adapter for highly reactive gases
- Detcon Span Gas (See Detcon for Ordering Information). Recommended span gas is 50% of range with target gas. Other suitable span gas sources containing the target gas in air or N₂ balance are acceptable.
- DVM (if a loop powered display is not installed)

NOTE: The cover of the junction box will need to be removed if there is not a loop powered display. The area may need to be de-classified.

NOTE: Contact Detcon for Ordering Information on Span Gas cylinders.

NOTE: A target gas concentration of 50% of range is strongly recommended. This should be applied at a controlled flow rate of 200 to 500cc/min, with 500cc/min being the recommended flow rate. Other concentrations can be used if they fall within allowable levels of 10% to 100% of range.

NOTE: Ambient air should be used to calibrate O₂ deficiency sensors as long as the oxygen concentration is confirmed to be 20.9%

NOTE: It is generally not advised to use other gases to cross-calibrate for span. Cross-calibration by use of other gases should be confirmed by Detcon.

Span consists of applying the correct gas concentration at the correct flow rate, and adjusting the sensor for the proper output. The recommendation for span gas concentration is 50% of range. If a span gas containing the recommended concentration is not available, other concentrations may be used as long as they fall between 10% and 100% of range.

1. If a Loop Powered Display is not installed on the sensor, set a DVM up to measure millivolts, and connect it across TP1 and TP2 on the terminal board. The DVM will read the voltage drop across a 10Ω resistor. The resistor develops a 10mV voltage drop per 1mA of current. Thus a reading of 40mV on the DVM equals 4mA of current.
2. Install the Calibration Wind Guard, or the appropriate calibration adapter.
3. From Normal Operation, hold the programming magnet over PGM2 for greater than three seconds. The display (if connected) will display will flash "CAL" three times and then should display '0.0' and will flash at a rate of once per second. If a meter is attached, the reading will dip to 2mA (20mV on the meter).
4. Apply the span calibration test gas for toxic gas sensors at a flow rate of 200-500cc/min (500cc/min is the recommended flow rate). The DVM reading or display will remain at 2mA or "0" for 2 minutes.

5. When the 2 minute wait is complete, the reading will increase to a level that corresponds to the level of gas the plug-in sensor is detecting. There is a 30 second period to decide if the reading needs to be adjusted. If the reading matches the level of gas applied skip to step 7.
6. To adjust the reading, hold the programming magnet over PGM2. The display (if connected) will start to increase. If a meter is attached, the reading will also start to increase. Continue to hold the programming magnet over PGM2 to make the current increase, or hold the magnet over PGM1 to make the current decrease. Use PGM1 and PGM2 to adjust the output to match the target gas set-point. Assuming 50% of full range was applied, adjust the reading to 12mA (120mV on the DVM, or 50% of full range on the display).

NOTE: 12mA and 50% of full range are based on the use of a span gas concentration of 50%. If a different concentration of span gas is used, the mA reading will need to be calculated. I.E. if a 25% concentration span gas is used the reading would be 8mA and the display would be 25% of full range. Use the magnetic tool to adjust the mA reading to the target set-point.

7. When the correct adjustment has been made, wait 15 seconds without holding the programming magnet over either PGM1 or PGM2. The display (if connected) will flash “CAL” three times then return to the target reading. If a meter is attached, the reading will momentarily decrease about 20% and then return to the target reading. This indicates that the span calibration point has been successfully saved. If a lack of proper signal level change is internally detected the sensor will immediately go into fault. The display (if connected) will show “Fxx” (where xx is the error code). If a meter is attached, the reading will go to 0ma. Only a successful re-calibration will clear this fault. Refer to section 5 Troubleshooting Guide).
8. Remove the span gas and calibration adapter (or calibration wind guard). If a display is installed the display will report a live reading as the sensor clears toward “0”. On the DVM, the reading will fall from the reported span level to 4mA (40mV). The sensor now allows 5 minutes for the reading to clear below 10% of full scale range (5.6mA). If the reading does not meet the clearing test criteria the sensor will go into fault. The display (if connected) will show “Fxx” (where xx is the error code). If a meter is attached, the reading will go to 0ma. Only a successful re-calibration will clear this fault. (Refer to section 5 Troubleshooting Guide)
9. Span calibration is complete. If the Splash Guard was removed for calibration, re-install the Splash Guard.

3.3 Fault Diagnostic/Failsafe Feature

If the ITM should incur a fault, the ITM will drop the mA output to 0mA. This can occur if the ITM detects a problem with the sensor, detects that there is no sensor connected, or if the ITM has an internal fault. The ITM will hold this 0mA output until the problem is resolved. If the 100 Series Display is installed, the display will show an error code. The error codes are defined in section 5 Troubleshooting Guide.

4. Service and Maintenance

Calibration Frequency

In most applications, monthly to quarterly span calibration intervals will assure reliable detection. However, industrial environments differ. Upon initial installation and commissioning, close frequency tests should be performed, weekly to monthly. Test results should be recorded and reviewed to determine a suitable calibration interval.

Visual Inspection

The Sensor should be inspected annually:

- ❖ Inspect the sensor for signs of corrosion, pitting, and water damage.
- ❖ Remove the Splash Guard and inspected it for blockage, broken, cracked, or missing pieces.
- ❖ For H2S Sensor assemblies, inspect 100 Series Bottom Housing Assembly with integral filter (P/N 602-003552-100) for blockage of filter material.
- ❖ Inspect inside of the Junction Box for signs of water accumulation, signs of corrosion.
- ❖ Check wiring to ensure there are no loose or pinched wires and all connections are clean and tight.

Condensation Prevention Packet

A moisture condensation packet should be installed in every explosion proof Junction Box. The moisture condensation prevention packet will prevent the internal volume of the J-Box from condensing and accumulating moisture due to day-night humidity changes. This packet provides a critical function and should be replaced annually. Detcon's PN is 960-202200-000.

4.1 Replacement of Plug-in Sensor

NOTE: It is not necessary to remove power while changing the plug-in toxic gas sensor in order to maintain area classification, since it is intrinsically safe.

NOTE: Only replace the plug-in sensor with an authorized DM-100 family of gas sensors.

1. Use a 1/8" Allen wrench to release the locking cap head screw that locks the ITM and Splash Guard Adapter together (One turn will suffice - Do not remove cap head screw completely).
2. Unthread and remove the Splash Guard Adapter and Splash Guard from the ITM.
3. Gently pull the plug-in sensor out of the ITM. Orient the new plug-in sensor so that it matches with the female connector pins. Use the alignment marks provided to assure alignment is correct. When properly aligned, press the sensor in firmly to make the proper connection.
4. Thread the Splash Guard Adapter onto the ITM to a snug fit and tighten the locking cap head screw using the 1/8" Allen wrench. Reinstall the Splash Guard.
5. Check and perform zero calibration and span calibration as per Section 3.2 Calibration.

4.2 Replacement of ITM

1. Remove the power source to the sensor assembly. Disconnect all sensor wire connections at the Junction Box Terminal Board taking note of the wire connections.

NOTE: It is necessary to remove power to the Junction box while changing the ITM in order to maintain area classification.

2. Use a wrench and the wrench flats provided at the top section of the ITM and unthread the ITM until it can be removed.
3. Use a 1/8" Allen wrench to release the locking cap head screw that locks the ITM and Splash Guard Adapter together (One turn will suffice - Do not remove setscrew completely).
4. Unthread and remove the Splash Guard Adapter and Splash Guard from the ITM. These will be re-used with the new ITM.
5. Gently remove the plug-in toxic gas sensor from the old ITM and install it in the new ITM. Orient the plug-in sensor so that it matches the female connector pins on the new ITM and press the sensor in firmly to make proper connection.
6. Thread the Splash Guard Adapter onto the new ITM until snug, tighten the locking cap head screw and reinstall Splash Guard.
7. Feed the sensor assembly wires through the 3/4" female NPT mounting hole and thread the assembly into the J-box until tight and the ITM faces toward the front access point. Use the locking nut to secure the ITM in this position. Connect the sensor assembly wires to the terminal board inside the Junction Box (Refer to Section 2.6).
8. Check and/or perform Zero Calibration and Span Calibration per sections 3.2 Calibration.

4.3 Replacement of the Model 100 Terminal Board

1. Remove the power source to the sensor assembly.

NOTE: It is necessary to remove power to the Junction Box while changing the Model 100 Terminal Board in order to maintain area classification.

2. Remove the junction box cover and remove the Loop Powered Display, if one is installed.
3. Remove the J5 power connector on the terminal board.
4. Unplug all other connectors from the terminal board, noting where they are plugged in.
5. Remove the four 6-32 screws holding the terminal board to the base of the junction box and remove the terminal board.
6. Install the new terminal board using the four 6-32 screws removed in step 5.
7. If the unit has the Model 100 Display Terminal Board, ensure that the jumper on the terminal board is set properly (Refer to section 2.6.1 Model 100 Display Terminal Board Settings).
8. Re-connect the sensor connector to the terminal board and all other connections removed in step 4.
9. Reconnect the J5 power connector to the terminal board.
10. Re-install the Loop Powered Display, if one was installed.

11. Reinstall the junction box cover, and restore power to the sensor.
12. Check operation of sensor assembly. (see section 2.7 Initial Start Up)

5. Troubleshooting Guide

If the ITM detects any functional errors the ITM will bring the mA output to 0mA and hold it there until the problem has been resolved. If the unit has a Display, the display will show an error code. Error codes are displayed as “Fxx” where xx is the actual error code.

The Display Error Codes are:

F01	Auto Span Fault
F02	Temperature Fault
F03	4-20mA Fault
F04	Input Voltage Fault
F05	ITM Memory Fault
F06	Processor Fault
F07	Clearing Fault
F08	Stability Fault
F09	Range Fault
F10	Sensor Fault
F11	Zero Fault
F12	Sensor Fault 2

Some faults are self explanatory, and if these faults occur and cannot be cleared the ITM should be replaced first to see if the fault will clear. These faults would be indicative of F05 and F06. Other faults may need further investigation. Some of the sensor problems, associated error codes, and resolutions are listed below.

Under-Range problems (F11)

Probable Cause: Sensor Baseline drifted lower, Interference gases,
Perform Zero Calibration. Use Zero Air or N₂ source. (Section 3.2.1 Zero Calibration)
Allow more time for zero stabilization if this is a biased sensor type.
Execute successful Span Calibration. (Section 3.2.2 Span Calibration)
Replace plug-in toxic sensor if error continues.

Stability problems (F08)

Probable Causes: Failed Sensor, empty or close to empty Cal Gas Cylinder, problems with cal gas and delivery
Check validity of span gas using pull tube or other means (check MFG date on cal gas cylinder).
Use proper cal gas regulators and tubing for highly corrosive gases
Check for obstructions affecting cal gas hitting sensor face (including being wet, blocked, or corroded). H2S sensors assemblies use 100 Series Bottom Housing Assembly with integral filter. Clean or replace if necessary.
Replace the plug-in toxic sensor.

Clearing problem (F07)

Probable Causes: Failed Sensor, Cal Gas not removed at appropriate time, problems with cal gas and delivery, Background of Target Gas.
The sensor must recover to < 5% of range in < 5 min after Span calibration is complete
Use bottled air (zero air or N₂) if there is a known continuous background level.
Check validity of span gas using pull tube or other means (check MFG date on cal gas cylinder).
Use proper cal gas regulators and tubing for highly corrosive gases
Check for obstructions affecting cal gas hitting sensor face (including being wet, blocked, or corroded). H2S sensors assemblies use 100 Series Bottom Housing Assembly with integral filter. Clean or replace if necessary.

Replace the plug-in toxic sensor.

Poor Calibration Repeatability (F09)

Probable Causes: Failed Sensor, use of wrong Cal Gas or problems w/ cal gas and delivery, Interference Gases
Check validity of span gas with regulator and sample tubing in place using pull tube or other means (check MFG date on cal gas cylinder).

Use proper cal gas regulators and tubing for highly corrosive gases (HF, HCl, Cl₂, NH₃, HBR, F₂, etc.)

Check for obstructions affecting cal gas hitting sensor face (including being wet, blocked, or corroded). H₂S sensors assemblies use 100 Series Bottom Housing Assembly with integral filter. Clean or replace if necessary.

Replace the plug-in toxic sensor.

Unstable Output/ sudden spiking (F03, F04)

Possible Causes: Unstable power supply, inadequate grounding, or inadequate RFI protection.

Verify Power source is stable.

Verify field wiring is properly shielded and grounded.

Contact Detcon to optimize shielding and grounding.

Add Detcon's RFI Protection Circuit accessory if problem is proven RFI induced.

Nuisance Alarms

Check conduit for accumulated water and abnormal corrosion on terminal board.

If nuisance alarms are happening at night, suspect condensation in conduit.

Add or replace Detcon's Condensation Prevention Packet P/N 960-202200-000.

Investigate the presence of other target gases that are causing cross-interference signals.

Determine if cause is RFI induced.

Unreadable Display (if a Loop Power Display is installed)

If due to excessive sunlight, install a sunshade to reduce glare.

Replace Display Assembly

Replace 100 Series Display.

Blank or incorrect reading on Display (if a 100 Series Display is installed)

ITM has an internal fault, problem with display.

Swap with a known-good ITM to determine if ITM is faulty.

Swap Model 100 Display Terminal Board with known good board

Swap Model 100 Display with known good display.

Transmitter not responding (F05, F06)

Verify conduit has no accumulated water or abnormal corrosion.

Verify required DC power is applied to correct terminals.

Swap with a known-good ITM to determine if ITM is faulty.

Faulty 4-20mA Output (F03)

Check that wiring is properly connected at terminal board and through to controller inputs.

The 4-20 output loop must be closed (resistance of < 750 ohms).

If the 4-20mA signal output is 0mA to 2mA, there is an ITM fault.

Swap with new ITM to determine if the ITM is faulty.

6. Customer Support and Service Policy

Detcon Headquarters

Shipping Address: 3200 A-1 Research Forest Dr., The Woodlands Texas 77381

Mailing Address: P.O. Box 8067, The Woodlands Texas 77387-8067

Phone: 888.367.4286, or 281.367.4100

Fax: 281.292.2860

- www.detcon.com
- service@detcon.com
- sales@detcon.com

All Technical Service and Repair activities should be handled by the Detcon Service Department via phone, fax or email at contact information given above. RMA numbers should be obtained from the Detcon Service Department prior to equipment being returned. For on-line technical service, customers should have ready the model number, part number, and serial number of product(s) in question.

All Sales activities (including spare parts purchase) should be handled by the Detcon Sales Department via phone, fax or email at contact information given above.

Warranty Notice

Detcon Inc. warrants the Model DM-100 gas sensor to be free from defects in workmanship of material under normal use and service for two years from the date of shipment on the transmitter electronics. See Warranty details in section 7 DM-100 Sensor Warranty.

Detcon Inc. will repair or replace without charge any such equipment found to be defective during the warranty period. Full determination of the nature of, and responsibility for, defective or damaged equipment will be made by Detcon Inc. personnel.

Defective or damaged equipment must be shipped to the Detcon Inc. factory or representative from which the original shipment was made. In all cases, this warranty is limited to the cost of the equipment supplied by Detcon Inc. The customer will assume all liability for the misuse of this equipment by its employees or other contracted personnel.

All warranties are contingent upon the proper use in the application for which the product was intended and does not cover products which have been modified or repaired without Detcon Inc. approval, or which have been subjected to neglect, accident, improper installation or application, or on which the original identification marks have been removed or altered.

Except for the express warranty stated above, Detcon Inc. disclaims all warranties with regard to the products sold. Including all implied warranties of merchantability and fitness and the express warranties stated herein are in lieu of all obligations or liabilities on the part of Detcon Inc. for damages including, but not limited to, consequential damages arising out of, or in connection with, the performance of the product.

7. DM-100 Sensor Warranty

Plug-in Sensor Warranty

Detcon Inc. warrants, under normal intended use, each new intelligent plug-in sensor per the period specified in the Warranty column of Table 3 Sensor Specific Data (See section 8.2 Sensor Specific Data) and under the conditions described as follows: The warranty period begins on the date of shipment to the original purchaser. The sensor element is warranted to be free of defects in material and workmanship. Should any sensor fail to perform in accordance with published specifications within the warranty period, return the defective part to Detcon, Inc., 3200 A-1 Research Forest Dr., The Woodlands, Texas 77381, for necessary repairs or replacement.

Terms & Conditions

- The original serial number must be legible on each sensor element base.
- Shipping point is FOB the Detcon factory.
- Net payment is due within 30 days of invoice.
- Detcon, Inc. reserves the right to refund the original purchase price in lieu of sensor replacement.

ITM Electronics Warranty

Detcon Inc. warrants, under intended normal use, each new Model 100 ITM to be free from defects in material and workmanship for a period of two years from the date of shipment to the original purchaser. All warranties and service policies are FOB the Detcon facility located in The Woodlands, Texas.

Terms & Conditions

- ❖ The original serial number must be legible on each ITM.
- ❖ Shipping point is FOB the Detcon factory.
- ❖ Net payment is due within 30 days of invoice.
- ❖ Detcon, Inc. reserves the right to refund the original purchase price in lieu of ITM replacement.

8. Appendix

8.1 Specifications

System Specifications

Sensor Type:	Continuous diffusion/adsorption type 3-Electrode Electrochemical Sensor (2-Electrode for O ₂) Plug-in Replaceable Type
Sensor Life:	2 years typical
Measuring Ranges:	0-1ppm up to 0-10,000ppm (Toxic Gases) 0-1% up to 0-25% volume (O ₂)
Accuracy/ Repeatability:	±2% of full-range (other Toxic Gases) ±1% of full-range (O ₂)
Response Time:	T90 < 30 seconds typical (See Sensor Table)
Electrical Classification:	CSA and US (NRTL) Class I, Division 1, Groups A, B, C, D ATEX Class I, Zone 1, Group IIC Ex d [ib] ib IIC T6
Approvals:	cCSA _{US} , ATEX, CE Marking
Warranty:	Electronics – 2 years Sensor – See Table 3 Sensor Specific Data

Environmental Specifications

Operating Temperature:	-40°C to +50°C typical (See Table 3 Sensor Specific Data)
Storage Temperature:	-35°C to +55°C typical
Operating Humidity:	10-95% RH Continuous Duty (See Table 3 Sensor Specific Data) 0-100% RH Short-Term Duration Only
Operating Pressure:	Ambient ± 10%
Air Velocity:	0-5 meters/second

Electrical Specifications

Input Voltage:	10-28 VDC
Power Consumption:	Normal operation = 4 mA (0.1 watts @ 24VDC); Maximum = 20 mA (0.5 watts @ 24VDC; 0.23 watts @ 11.5VDC)
RFI/EMI Protection:	Complies with EN61326

Analog Output: Linear 4-20mA DC current
 750 ohms maximum loop load @ 24VDC
 1.2 mA All Fault Diagnostics
 4-20 mA 0-100% full-scale
 22 mA Over-range condition

Cable Requirements: Power/Analog: 2-wire shielded cable
 Maximum distance is 13,300 feet with 14 AWG

Mechanical Specifications

Length: 5.165 inches (131 mm), 8.5 inches (215mm) with Splash Guard

Width: 2.2 inches (55 mm)

Weight: 2.5 lbs (1.2 Kg)

Mechanical Connection: 3/4" Male NPT threaded connection with locking nut

Electrical Connection: four 18 gauge wire leads - 5.5" long

8.2 Sensor Specific Data

Table 3 Sensor Specific Data

Gas	GasName	Part Number ¹	Response Time (seconds)	SpanDrift	Temperature Range °C	Humidity Range%	Warranty
O ₂	Oxygen	371-343400-025	T95<30	<5%signal loss/year	-20 to+50	15 to 90	2 years
C ₂ H ₃ O	Acetyldehyde	371-12EA00-100	T90<140	<5%signal loss/year	-20 to+50	15 to 90	2 years
C ₂ H ₂	Acetylene	371-12EG00-100	T90<140	<5%signal loss/year	-20 to+50	15 to 90	2 years
C ₃ H ₃ N	Acrylonitrile	371-12EM00-100	T90<140	<5%signal loss/year	-20 to+50	15 to 90	2 years
NH ₃	Ammonia	371-171700-100	T90<90	<2%signal loss/month	-20 to+50	15 to 90	2 years
AsH ₃	Arsine	371-191900-001	T90<60	<5%signal loss/month	-20 to+40	20 to 95	1.5 years
Br ₂	Bromine	371-747500-005	T90<60	<2%signal loss/month	-20 to+50	15 to 90	2 years
C ₄ H ₆	Butadiene	371-12EB00-100	T90<140	<5%signal loss/year	-20 to+50	15 to 90	2 years
CO	Carbon Monoxide	371-444400-100	T90=30	<5%signal loss/year	-40 to+50	15 to 90	3 years
Cl ₂	Chlorine	371-747400-010	T90<60	<2%signal loss/month	-20 to+50	15 to 90	2 years
ClO ₂ (>10ppm)	Chlorine Dioxide	371-777700-001	T90<60	<2%signal loss/month	-20 to+50	15 to 90	2 years
ClO ₂ (<=10ppm)	Chlorine Dioxide	371-282800-050	T90<120	<1%signal loss/month	-20 to+40	10 to 95	2 years
B ₂ H ₆	Diborane	371-192100-005	T90<60	<5%signal loss/month	-20 to+40	20 to 95	1.5 years
C ₂ H ₅ OH	Ethanol	371-12EO00-100	T90<140	<5%signal loss/year	-20 to+50	15 to 90	2 years
C ₂ H ₅ SH	Ethyl Mercaptan	371-24EZ00-100	T90<45	<2%signal loss/month	-40 to+50	15 to 90	2 years

¹ The last three digits of the Part Number are the range of the sensor cell. I.E. "-100" is a 100ppm range.

Gas	GasName	Part Number ¹	Response Time (seconds)	SpanDrift	Temperature Range °C	Humidity Range%	Warranty
C₂H₄	Ethylene	371-12ED00-100	T90<140	<5%signal loss/year	-20 to+50	15 to 90	2 years
C₂H₄O	Ethylene Oxide	371-12EJ00-100	T90<140	<5%signal loss/year	-20 to+50	15 to 90	2 years
F₂	Fluorine	371-272700-001	T90<80	<5%signal loss/year	-10 to+40	10 to 95	1.5 years
CH₂O	Formaldehyde	371-12EP00-100	T90<140	<5%signal loss/year	-20 to+50	15 to 90	2 years
GeH₄	Germane	371-232500-002	T90<60	<1%signal loss/month	-20 to+40	20 to 95	1.5 years
N₂H₄	Hydrazine	371-262600-001	T90<120	<5%signal loss/month	-10 to+40	10 to 95	1 year
H₂ (ppm)	Hydrogen	371-848400-100	T90=30	<2%signal loss/month	-20 to+50	15 to 90	2 years
H₂ (LEL)*	Hydrogen	371-050500-04P	T90<60	<2%signal loss/month	-40 to+40	5 to 95	2 years
HBr	Hydrogen Bromide	371-090800-030	T90<70	<3%signal loss/month	-20 to+40	10 to 95	1.5 years
HCl	Hydrogen Chloride	371-090900-030	T90<70	<2%signal loss/month	-20 to+40	10 to 95	1.5 years
HCN	Hydrogen Cyanide	371-131300-030	T90<40	<5%signal loss/month	-40 to+40	5 to 95	2 years
HF	Hydrogen Fluoride	371-333300-010	T90<90	<10%signal loss/month	-20 to+35	10 to 80	1.5 years
H₂S	Hydrogen Sulfide	371-242400-100	T80<30	<2%signal loss/month	-40 to+50	15 to 90	2 years
CH₃OH	Methanol	371-12EE00-100	T90<140	<5%signal loss/year	-20 to+50	15 to 90	2 years
CH₃SH	Methyl Mercaptan	371-24EK00-100	T90<45	<2%signal loss/month	-40 to+50	15 to 90	2 years
NO	Nitric Oxide	371-949400-100	T90=10	<2%signal loss/month	-20 to+50	15 to 90	3 years
NO₂	Nitrogen Dioxide	371-646400-010	T90<40	<2%signal loss/month	-20 to+50	15 to 90	2 years
O₃	Ozone	371-999900-001	T90<120	<1%signal loss/month	-10 to+40	10 to 95	2 years
COCl₂	Phosgene	371-414100-001	T90<120	<1%signal loss/month	-20 to+40	10 to 95	1.5 years
PH₃	Phosphine	371-192000-005	T90<30	<1%signal loss/month	-20 to+40	20 to 95	1.5 years
SiH₄	Silane	371-232300-050	T90<60	<1%signal loss/month	-20 to+40	20 to 95	1.5 years
SO₂	SulfurDioxide	371-555500-020	T90=20	<2%signal loss/month	-20 to+50	15 to 90	2 years
C₄H₆O₂	Vinyl Acetate	371-12EF00-100	T90<140	<5%signal loss/year	-20 to+50	15 to 90	2 years
C₂H₃Cl	Vinyl Chloride	371-12EL00-100	T90<140	<5%signal loss/year	-20 to+50	15 to 90	2 years

8.3 Interference Table

Reference Table 4 Interfering Gases to match the interfering gas symbol with the gas name. Then refer to Table 5 Cross Interference Table which extends for 5 pages, with each sensor specific gas repeated in each section of the table, for a column listing of 40 gases. The list is followed by a row of 14 possible interfering gases per page. Review each page for the applicable sensor gas and then scan across the row for possible interference gases.

Table 4 Interfering Gases

Acetylidehyde	C ₂ H ₃ O	Dimethyl Sulfide	C ₂ H ₆ S	Methane	CH ₄
Acetylene	C ₂ H ₂	Disilane	Si ₂ H ₆	Methanol	CH ₃ OH
Acrylonitrile	C ₃ H ₃ N	Epichlorohydrin	C ₃ H ₅ OCl	Methyl-ethyl-ketone	C ₄ H ₈ O
Alcohols	Alcohols	Ethanol	C ₂ H ₅ OH	Methyl Mercaptan	CH ₃ SH
Amines	Amines	Ethyl Mercaptan	C ₂ H ₅ SH	Nitric Oxide	NO
Ammonia	NH ₃	Ethylene	C ₂ H ₄	Nitrogen	N ₂
Arsenic Trifluoride	AsF ₃	Ethylene Oxide	C ₂ H ₄ O	Nitrogen Dioxide	NO ₂
Arsenic Pentafluoride	AsF ₅	Fluorine	F ₂	Ozone	O ₃
Arsine	AsH ₃	Formaldehyde	CH ₂ O	Phosgene	COCl ₂
Boron Trifluoride	BF ₃	Germane	GeH ₄	Phosphine	PH ₃
Bromine	Br ₂	Hydrazine	N ₂ H ₄	Phosphorous Trifluoride	PF ₃
Butadiene	C ₄ H ₆	Hydrocarbons	C-H's	Silane	SiH ₄
Buten-1	Buten-1	Hydrocarbons (unsaturated)	C-H's (μ)	Silicon	Si
Carbon Dioxide	CO ₂	Hydrogen	H ₂	Silicon Tetra Fluoride	SiF ₄
Carbon Disulfide	CS ₂	Hydrogen Bromide	HBr	Sulfur Dioxide	SO ₂
Carbon Oxide Sulfide	COS	Hydrogen Chloride	HCl	Tetrahydrothiophene	C ₄ H ₈ S
Carbon Monoxide	CO	Hydrogen Cyanide	HCN	Thiophane	C ₄ H ₄ S
Carbonyl Sulfide	CS	Hydrogen Fluoride	HF	Toluene	C ₆ H ₅ CH ₃
Chlorine	Cl ₂	Hydrogen Selenide	HSe	Tungsten Hexafluoride	WF ₆
Chlorine Dioxide	ClO ₂	Hydrogen Sulfide	H ₂ S	Vinyl Acetate	C ₄ H ₆ O ₂
Chlorine Trifluoride	ClF ₃	Dimethyl Sulfide	C ₂ H ₆ S	Vinyl Chloride	C ₂ H ₃ Cl
Diborane	B ₂ H ₆	Disilane	Si ₂ H ₇		

Table 5 Cross Interference Table

Gas	C ₂ H ₃ O	C ₂ H ₂	C ₃ H ₃ N	Alcohols	Amines	NH ₃	AsF ₃	AsF ₅	AsH ₃	BF ₃	Br ₂	C ₄ H ₆	Buten-1
C ₂ H ₃ O	n/a	40=340	40=75	n/d	n/d	n/d	n/d	n/d	n/d	n/d	n/d	40=170	n/d
C ₂ H ₂	340=40	n/a	340=75	n/d	n/d	n/d	n/d	n/d	n/d	n/d	n/d	340=170	n/d
C ₃ H ₃ N	75=40	75=340	n/a	n/d	n/d	n/d	n/d	n/d	n/d	n/d	n/d	75=170	n/d
NH ₃	n/d	n/d	n/d	n/d	n/d	n/d	n/d	n/d	n/d	n/d	n/d	n/d	n/d
AsH ₃	n/d	n/d	n/d	n/d	n/d	100=0.01	n/d	n/d	n/a	n/d	n/d	n/d	n/d
Br ₂	n/d	n/d	n/d	n/d	n/d	n/d	n/d	n/d	n/d	n/d	n/a	n/d	n/d
C ₄ H ₆	170=40	170=340	170=75	n/d	n/d	n/d	n/d	n/d	n/d	n/d	n/d	n/a	n/d
CS ₂	140=40	140=340	140=75	n/d	n/d	n/d	n/d	n/d	n/d	n/d	n/d	140=170	n/d
CO	n/d	n/d	n/d	n/d	n/d	n/d	n/d	n/d	n/d	n/d	n/d	n/d	n/d
Cl ₂	n/d	n/d	n/d	n/d	n/d	n/d	n/d	n/d	n/d	n/d	1=0.55	n/d	n/d
ClO ₂ (>10ppm)	n/d	n/d	n/d	n/d	n/d	n/d	n/d	n/d	n/d	n/d	1=0.18	n/d	n/d
ClO ₂ (=10ppm)	n/d	n/d	n/d	n/d	n/d	n/d	n/d	n/d	n/d	n/d	n/d	n/d	n/d
B ₂ H ₆	n/d	n/d	n/d	n/d	n/d	100=0.013	n/d	n/d	0.15=0.2	n/d	n/d	n/d	n/d
C ₃ H ₅ OCl	50=40	50=340	50=75	n/d	n/d	n/d	n/d	n/d	n/d	n/d	n/d	50=170	n/d
C ₂ H ₅ OH	180=40	180=340	180=75	n/d	n/d	n/d	n/d	n/d	n/d	n/d	n/d	180=170	n/d
C ₂ H ₅ SH	n/d	n/d	n/d	n/d	n/d	n/d	n/d	n/d	n/d	n/d	n/d	n/d	n/d
C ₂ H ₄	220=40	220=340	220=75	n/d	n/d	n/d	n/d	n/d	n/d	n/d	n/d	220=170	n/d
C ₂ H ₄ O	275=40	275=340	275=75	n/d	n/d	n/d	n/d	n/d	n/d	n/d	n/d	275=170	n/d
F ₂	n/d	n/d	n/d	1000=0	n/d	n/d	n/d	n/d	0.1=0	n/d	yes n/d	n/d	n/d
CH ₂ O	330=40	330=340	330=75	n/d	n/d	n/d	n/d	n/d	n/d	n/d	n/d	330=170	n/d
GeH ₄	n/d	n/d	n/d	n/d	n/d	100=<1	n/d	n/d	0.2=0.14	n/d	n/d	n/d	n/d
N ₂ H ₄	n/d	n/d	n/d	1000=0	n/d	200=0.04	n/d	n/d	0.1=0.1	n/d	n/d	n/d	n/d
H ₂ (ppm)	n/d	n/d	n/d	n/d	n/d	n/d	n/d	n/d	n/d	n/d	n/d	n/d	n/d
H ₂ (LEL)	n/d	n/d	n/d	n/d	n/d	100=0	n/d	n/d	n/d	n/d	n/d	n/d	n/d
HBr	n/d	n/d	n/d	1000=0	no	n/d	n/d	n/d	0.1=0.3	n/d	n/d	n/d	n/d
HCl	n/d	n/d	n/d	1000=0	no	n/d	n/d	n/d	0.1=0.3	n/d	n/d	n/d	n/d
HCN	n/d	n/d	n/d	1000=0	n/d	n/d	n/d	n/d	0.1=0	n/d	yes n/d	n/d	n/d
HF	n/d	n/d	n/d	1000=0	n/d	n/d	yes n/d	yes n/d	0.1=0	yes n/d	n/d	n/d	n/d
H ₂ S	n/d	n/d	n/d	n/d	n/d	n/d	n/d	n/d	n/d	n/d	n/d	n/d	n/d
CH ₃ OH	415=40	415=340	415=75	n/d	n/d	n/d	n/d	n/d	n/d	n/d	n/d	415=170	n/d
CH ₃ SH	n/d	n/d	n/d	n/d	n/d	n/d	n/d	n/d	n/d	n/d	n/d	275=170	n/d
NO	n/d	n/d	n/d	n/d	n/d	n/d	n/d	n/d	n/d	n/d	n/d	n/d	n/d
NO ₂	n/d	n/d	n/d	n/d	n/d	n/d	n/d	n/d	n/d	n/d	n/d	n/d	n/d
O ₃	n/d	n/d	n/d	n/d	n/d	n/d	n/d	n/d	0.1=0.05	n/d	yes n/d	n/d	n/d
COCl ₂	n/d	n/d	n/d	1000=0	n/d	50=0.5	n/d	n/d	n/d	n/d	n/d	n/d	n/d
PH ₃	n/d	n/d	n/d	n/d	n/d	100=0.01	n/d	n/d	1=1	n/d	n/d	n/d	n/d
SiH ₄	n/d	n/d	n/d	n/d	n/d	100=<1	n/d	n/d	0.2=0.14	n/d	n/d	n/d	n/d
SO ₂	n/d	n/d	n/d	n/d	n/d	n/d	n/d	n/d	n/d	n/d	n/d	n/d	n/d
C ₄ H ₆ O ₂	200=40	200=340	200=75	n/d	n/d	n/d	n/d	n/d	n/d	n/d	n/d	200=170	n/d
C ₂ H ₃ Cl	200=40	200=340	200=75	n/d	n/d	n/d	n/d	n/d	n/d	n/d	n/d	200=170	n/d

n/a – not applicable

n/d – no data

Table 5 Cross Interference Table (pg.2)

Gas	CO ₂	CS ₂	CO	COS	CL ₂	CLO ₂	CLF ₃	B ₂ H ₆	C ₂ H ₆ S	Si ₂ H ₆	C ₃ H ₅ OCL	C ₂ H ₅ OH	F ₂
C ₂ H ₃ O	n/d	40=140	40=100	40=135	n/d	n/d	n/d	n/d	40=150	n/d	40=50	40=180	n/d
C ₂ H ₂	n/d	340=140	340=100	340=135	n/d	n/d	n/d	n/d	340=150	n/d	340=50	340=180	n/d
C ₃ H ₃ N	n/d	75=140	75=100	75=135	n/d	n/d	n/d	n/d	75=150	n/d	75=50	75=180	n/d
NH ₃	n/d	n/d	300=8	n/d	1=-1	10%=-15	n/d	n/d	n/d	n/d	n/d	n/d	n/d
AsH ₃	5000=0	n/d	300=0	n/d	0.5=-0.04	n/d	n/d	0.2=0.15	n/d	5=yes n/d	n/d	n/d	n/d
Br ₂	n/d	n/d	300=0	n/d	1=2	1=6	n/d	n/d	n/d	n/d	n/d	n/d	n/d
C ₄ H ₆	n/d	170=140	170=100	170=135	n/d	n/d	n/d	n/d	170=150	n/d	170=50	170=180	n/d
CS ₂	n/d	n/a	140=100	140=135	n/d	n/d	n/d	n/d	140=150	n/d	140=50	140=180	n/d
CO	n/d	n/d	n/a	n/d	1=0	n/d	n/d	n/d	n/d	n/d	n/d	200=0	n/d
Cl ₂	n/d	n/d	300=0	n/d	n/a	n/d	n/d	n/d	n/d	n/d	n/d	n/d	n/d
ClO ₂ (>10ppm)	n/d	n/d	300=0	n/d	3=1	n/a	n/d	n/d	n/d	n/d	n/d	n/d	n/d
ClO ₂ (=10ppm)	5000=0	n/d	1000=0	n/d	1=0.9	n/a	yes n/d	0.1=0	n/d	n/d	n/d	n/d	yes n/d
B ₂ H ₆	5000=0	n/d	300=0	n/d	0.5=-0.05	n/d	n/d	n/a	n/d	5=yes n/d	n/d	n/d	n/d
C ₃ H ₅ OCl	n/d	50=140	50=100	50=135	n/d	n/d	n/d	n/d	50=150	n/d	n/a	50=180	n/d
C ₂ H ₅ OH	n/d	180=140	180=100	180=135	n/d	n/d	n/d	n/d	180=150	n/d	180=50	n/a	n/d
C ₂ H ₅ SH	n/d	n/d	300=5	n/d	1=-0.6	n/d	n/d	n/d	n/d	n/d	n/d	n/d	n/d
C ₂ H ₄	n/d	220=140	220=100	220=135	n/d	n/d	n/d	n/d	220=150	n/d	220=50	220=180	n/d
C ₂ H ₄ O	n/d	275=140	275=100	275=135	n/d	n/d	n/d	n/d	275=150	n/d	275=50	275=180	n/d
F ₂	5000=0	n/d	1000=0	n/d	1=1.3	n/d	n/d	n/d	n/d	n/d	n/d	n/d	n/a
CH ₂ O	n/d	330=140	330=100	330=135	n/d	n/d	n/d	n/d	330=150	n/d	330=50	330=180	n/d
GeH ₄	5000=0	n/d	300=0	n/d	0.5=-0.04	n/d	n/d	0.2=0.11	n/d	5=yes n/d	n/d	n/d	n/d
N ₂ H ₄	5000=0	n/d	1000=0	n/d	1=0	n/d	n/d	n/d	n/d	n/d	n/d	n/d	n/d
H ₂ (ppm)	n/d	n/d	300=<30	n/d	1=0	n/d	n/d	n/d	n/d	n/d	n/d	n/d	n/d
H ₂ (LEL)	1000=0	n/d	50=6	n/d	5=0	n/d	n/d	n/d	n/d	n/d	n/d	n/d	n/d
HBr	5000=0	n/d	1000=0	n/d	5=1	n/d	yes n/d	n/d	n/d	n/d	n/d	n/d	n/d
HCl	5000=0	n/d	1000=0	n/d	5=1	n/d	1=yes n/d	n/d	n/d	n/d	n/d	n/d	n/d
HCN	5000=0	n/d	1000=0	n/d	5=-1	n/d	n/d	n/d	n/d	n/d	n/d	n/d	n/d
HF	5000=0	n/d	1000=0	n/d	1=0.4	n/d	yes n/d	0.1=0	n/d	n/d	n/d	n/d	yes n/d
H ₂ S	n/d	n/d	300=1.5	n/d	1=-0.2	n/d	n/d	n/d	n/d	n/d	n/d	n/d	n/d
CH ₃ OH	n/d	415=140	415=100	415=135	n/d	n/d	n/d	n/d	415=150	n/d	415=50	415=180	n/d
CH ₃ SH	n/d	n/d	300=3	n/d	1=-0.4	n/d	n/d	n/d	n/d	n/d	n/d	n/d	n/d
NO	n/d	n/d	300=0	n/d	1=0	n/d	n/d	n/d	n/d	n/d	n/d	n/d	n/d
NO ₂	n/d	n/d	300=0	n/d	1=1	n/d	n/d	n/d	n/d	n/d	n/d	n/d	n/d
O ₃	5000=0	n/d	300=0	n/d	1=1.4	0.1=0.12	1=1(theory)	n/d	n/d	n/d	n/d	n/d	0.1=0.07
COCl ₂	5000=0	n/d	1000=0	n/d	1=0	n/d	n/d	n/d	n/d	n/d	n/d	n/d	n/d
PH ₃	5000=0	n/d	300=0	n/d	0.5=-0.04	n/d	n/d	0.2=0.15	n/d	5=yes n/d	n/d	n/d	n/d
SiH ₄	5000=0	n/d	300=0	n/d	0.5=-0.04	n/d	n/d	0.2=0.11	n/d	5=yes n/d	n/d	n/d	n/d
SO ₂	n/d	n/d	300=<5	n/d	1=<0.5	n/d	n/d	n/d	n/d	n/d	n/d	n/d	n/d
C ₄ H ₆ O ₂	n/d	200=140	200=100	200=135	n/d	n/d	n/d	n/d	200=150	n/d	200=50	200=180	n/d
C ₂ H ₃ Cl	n/d	200=140	200=100	200=135	n/d	n/d	n/d	n/d	200=150	n/d	200=50	200=180	n/d

n/a – not applicable

n/d – no data

Table 5 Cross Interference Table (pg.3)

Gas	C ₂ H ₄	C ₂ H ₆ O	CH ₂ O	GeH ₄	N ₂ H ₄	C-H's	C-H's (U)	H ₂	HBr	HCL	HCN	HF	I ₂
C ₂ H ₃ O	40=220	40=275	40=330	N/d	n/d	n/d	n/d	n/d	n/d	n/d	n/d	n/d	n/d
C ₂ H ₂	340=220	340=275	340=330	N/d	n/d	n/d	n/d	n/d	n/d	n/d	n/d	n/d	n/d
C ₂ H ₃ N	75=220	75=275	75=330	N/d	n/d	n/d	n/d	n/d	n/d	n/d	n/d	n/d	n/d
NH ₃	100=0	n/d	n/d	N/d	n/d	n/d	n/d	200=4	n/d	5=-3	10=0	n/d	n/d
AsH ₃	n/d	n/d	n/d	1=0.4	n/d	%range=0	n/d	3000=0	n/d	5=0	10=0.1	4=0	n/d
Br ₂	100=0	n/d	n/d	N/d	n/d	n/d	n/d	100=0	n/d	5=0	10=0	n/d	n/d
C ₄ H ₆	170=220	170=275	170=330	N/d	n/d	n/d	n/d	n/d	n/d	n/d	n/d	n/d	n/d
CS ₂	140=220	140=275	140=330	N/d	n/d	n/d	n/d	n/d	n/d	n/d	n/d	n/d	n/d
CO	100=<100	n/d	n/d	N/d	n/d	n/d	n/d	100=<60	n/d	5=0	10=<2	n/d	n/d
Cl ₂	100=0	n/d	n/d	N/d	n/d	n/d	n/d	100=0	n/d	5=0	10=0	n/d	n/d
ClO ₂ (>10ppm)	100=0	n/d	n/d	N/d	n/d	n/d	n/d	100=0	n/d	5=0	10=0	n/d	n/d
ClO ₂ (=10ppm)	n/d	n/d	n/d	1=0	n/d	%range=0	n/d	1%=0	n/d	n/d	n/d	n/d	n/d
B ₂ H ₆	n/d	n/d	n/d	1=0.53	n/d	%range=0	n/d	3000=0	n/d	5=0	10=0.13	4=0	n/d
C ₃ H ₅ OC1	50=220	50=275	50=330	N/d	n/d	n/d	n/d	n/d	n/d	n/d	n/d	n/d	n/d
C ₂ H ₅ OH	180=220	180=275	180=330	N/d	n/d	n/d	n/d	n/d	n/d	n/d	n/d	n/d	n/d
C ₂ H ₅ SH	100=0	n/d	n/d	N/d	n/d	n/d	n/d	1%=<15	n/d	5=0	10=0	n/d	n/d
C ₂ H ₄	n/a	220=275	220=330	n/d	n/d	n/d	n/d	n/d	n/d	n/d	n/d	n/d	n/d
C ₂ H ₄ O	275=220	n/a	275=330	n/d	n/d	n/d	n/d	n/d	n/d	n/d	n/d	n/d	n/d
F ₂	n/d	n/d	n/d	n/d	n/d	%range=0	n/d	1%=0	n/d	5=0	1=-3	3=0	n/d
CH ₂ O	330=220	330=275	n/a	n/d	n/d	n/d	n/d	n/d	n/d	n/d	n/d	n/d	n/d
GeH ₄	n/d	n/d	n/d	n/a	n/d	%range=0	n/d	3000=0	n/d	5=0	10=1	4=0	n/d
N ₂ H ₄	n/d	n/d	n/d	n/d	n/a	%range=0	n/d	1000=0	n/d	5=0.1	n/d	3=0	n/d
H ₂ (ppm)	100=˜80	n/d	n/d	n/d	n/d	n/d	n/d	n/a	n/d	5=0	10=˜3	n/d	n/d
H ₂ (LEL)	yes n/d	n/d	n/d	n/d	n/d	n/d	n/d	n/a	n/d	n/d	10=0	n/d	n/d
HBr	n/d	n/d	n/d	n/d	n/d	%range=0	n/d	1%=0	n/a	1=1	15=1	3=0	n/d
HCl	n/d	n/d	n/d	1=n/d	n/d	%range=0	n/d	1%=0	1=1	n/a	15=1	3=0	n/d
HCN	n/d	n/d	n/d	n/d	n/d	%range=0	n/d	1000=0	n/d	5=0	n/a	3=0	n/d
HF	n/d	n/d	n/d	1=0	n/d	%range=0	n/d	1%=0	n/d	5=3.3	n/d	n/a	n/d
H ₂ S	100=0	n/d	n/d	n/d	n/d	n/d	n/d	1%=<5	n/d	5=0	10=0	n/d	n/d
CH ₃ OH	415=220	415=275	415=330	n/d	n/d	n/d	n/d	n/d	n/d	n/d	n/d	n/d	n/d
CH ₃ SH	100=0	n/d	n/d	n/d	n/d	n/d	n/d	1%=<10	n/d	5=0	10=0	n/d	n/d
NO	100=0	n/d	n/d	n/d	n/d	n/d	n/d	100=0	n/d	5=<1	10=0	n/d	n/d
NO ₂	100=0	n/d	n/d	n/d	n/d	n/d	n/d	100=0	n/d	5=0	10=0	n/d	n/d
O ₃	n/d	n/d	n/d	n/d	n/d	n/d	n/d	1%=0.003	n/d	10=0	10=0.03	5=0	yes n/d
COCl ₂	n/d	n/d	n/d	n/d	n/d	%range=0	n/d	1%=0	n/d	5=0	5=0	3=0	n/d
PH ₃	n/d	n/d	n/d	1=0.4	n/d	%range=0	n/d	3000=0	n/d	5=0	10=0.1	4=0	n/d
SiH ₄	n/d	n/d	n/d	1=1.0	n/d	%range=0	n/d	3000=0	n/d	5=0	10=1	4=0	n/d
SO ₂	100=0	n/d	n/d	n/d	n/d	n/d	n/d	100=0	n/d	5=0	10=<5	n/d	n/d
C ₄ H ₆ O ₂	200=220	200=275	200=330	n/d	n/d	n/d	n/d	n/d	n/d	n/d	n/d	n/d	n/d
C ₂ H ₃ Cl	200=220	200=275	200=330	n/d	n/d	n/d	n/d	n/d	n/d	n/d	n/d	n/d	n/d

n/a – not applicable

n/d – no data

Table 5 Cross Interference Table (pg.4)

Gas	HSe	H ₂ S	C ₃ H ₈ O	CH ₄	CH ₃ OH	C ₄ H ₈ O	CH ₃ SH	NO	N ₂	NO ₂	O ₃	COCl ₂	PH ₃
C ₂ H ₃ O	n/d	n/d	n/d	n/d	40=415	n/d	40=275	n/d	n/d	n/d	n/d	n/d	n/d
C ₂ H ₂	n/d	n/d	n/d	n/d	340=415	n/d	340=275	n/d	n/d	n/d	n/d	n/d	n/d
C ₃ H ₃ N	n/d	n/d	n/d	n/d	75=415	n/d	75=275	n/d	n/d	n/d	n/d	n/d	n/d
NH ₃	n/d	15=30	n/d	n/d	n/d	n/d	n/d	35=6	n/d	5=-1	n/d	n/d	n/d
AsH ₃	0.05=0.005	1=0	n/d	n/d	n/d	n/d	n/d	n/d	100%=0	n/d	n/d	n/d	0.1=0.11
Br ₂	n/d	15=-1.5	n/d	n/d	n/d	n/d	n/d	35=0	n/d	5=-10	n/d	n/d	n/d
C ₄ H ₆	n/d	n/d	n/d	n/d	170=415	n/d	170=275	n/d	n/d	n/d	n/d	n/d	n/d
CS ₂	n/d	n/d	n/d	n/d	140=415	n/d	140=275	n/d	n/d	n/d	n/d	n/d	n/d
CO	n/d	15<0.3	n/d	n/d	n/d	n/d	n/d	35==7	n/d	5=0.5	n/d	n/d	n/d
Cl ₂	n/d	15=-0.75	n/d	n/d	n/d	n/d	n/d	35=0	n/d	5=5	n/d	n/d	n/d
ClO ₂ (>10ppm)	n/d	15=0.25	n/d	n/d	n/d	n/d	n/d	35=0	n/d	5=1.66	n/d	n/d	n/d
ClO ₂ (=10ppm)	n/d	10=-0.015	n/d	n/d	n/d	n/d	n/d	n/d	n/d	yes n/d	yes n/d	n/d	n/d
B ₂ H ₆	0.05=0.006	1=0	n/d	n/d	n/d	n/d	n/d	n/d	100%=0	n/d	n/d	n/d	0.1=0.14
C ₃ H ₅ OC1	n/d	n/d	n/d	n/d	50=415	n/d	50=275	n/d	n/d	n/d	n/d	n/d	n/d
C ₂ H ₅ OH	n/d	n/d	n/d	n/d	180=415	n/d	180=275	n/d	n/d	n/d	n/d	n/d	n/d
C ₂ H ₅ SH	n/d	1:03	n/d	n/d	n/d	n/d	5=8	35=<6	n/d	5=-1.5	n/d	n/d	n/d
C ₂ H ₄	n/d	n/d	n/d	n/d	220=415	n/d	220=275	n/d	n/d	n/d	n/d	n/d	n/d
C ₂ H ₄ O	n/d	n/d	n/d	n/d	275=415	n/d	275=275	n/d	n/d	n/d	n/d	n/d	n/d
F ₂	n/d	1=-1.5	n/d	n/d	n/d	n/d	n/d	n/d	100%=0	1=0.05	0.1=0.2	n/d	n/d
CH ₂ O	n/d	n/d	n/d	n/d	330=415	n/d	330=275	n/d	n/d	n/d	n/d	n/d	n/d
GeH ₄	0.05=0.005	1=0	n/d	n/d	n/d	n/d	n/d	n/d	100%=0	n/d	n/d	n/d	0.1=0.13
N ₂ H ₄	n/d	1=0.1	n/d	n/d	n/d	n/d	n/d	n/d	100%=0	1=-0.25	0.1=-0.1	n/d	0.3=0.1
H ₂ (ppm)	n/d	15=<3	n/d	n/d	n/d	n/d	n/d	35=-10	n/d	5=0	n/d	n/d	n/d
H ₂ (LEL)	n/d	n/d	yes n/d	1%=0	n/d	n/d	n/d	yes n/d	n/d	10=0	n/d	n/d	n/d
HBr	0.1=0	10=2.75	n/d	n/d	n/d	n/d	n/d	n/d	100%=0	n/d	n/d	0.1=0	0.1=0.3
HCl	0.1=0	10=2.75	n/d	n/d	n/d	n/d	n/d	n/d	100%=0	n/d	n/d	0.1=0	0.1=0.3
HCN	n/d	10=0	n/d	n/d	n/d	n/d	n/d	n/d	100%=0	10=-12	0.1=0	n/d	0.3=0
HF	n/d	10=0	n/d	n/d	n/d	n/d	n/d	n/d	100%=0	10=0.1	n/d	n/d	0.1=0
H ₂ S	n/d	n/a	n/d	n/d	n/d	n/d	2:01	35=<2	n/d	5=-0.5	n/d	n/d	n/d
CH ₃ OH	n/d	n/d	n/d	n/d	n/a	n/d	415=275	n/d	n/d	n/d	n/d	n/d	n/d
CH ₃ SH	n/d	1:02	n/d	n/d	n/d	n/d	n/a	35=<4	n/d	5=-1.0	n/d	n/d	n/d
NO	n/d	15=-5	n/d	n/d	n/d	n/d	n/d	100=0	n/d	5=<1.5	n/d	n/d	n/d
NO ₂	n/d	15=-0.75	n/d	n/d	n/d	n/d	n/d	35=0	n/d	n/a	n/d	n/d	n/d
O ₃	n/d	1=-.015	n/d	n/d	n/d	n/d	n/d	10=0	100%=0	1=0.7	n/a	n/d	0.3=0.03
COCl ₂	n/d	1=0	n/d	n/d	n/d	n/d	n/d	n/d	100%=0	n/d	n/d	n/a	0.3=0
PH ₃	0.05=0.005	1=0	n/d	n/d	n/d	n/d	n/d	n/d	100%=0	n/d	n/d	n/d	n/a
SiH ₄	0.05=0.005	1=0	n/d	n/d	n/d	n/d	n/d	n/d	100%=0	n/d	n/d	n/d	0.1=0.13
SO ₂	n/d	15=0	n/d	n/d	n/d	n/d	n/d	35=0	n/d	5=-5	n/d	n/d	n/d
C ₄ H ₆ O ₂	n/d	n/d	n/d	n/d	200=415	n/d	200=275	n/d	n/d	n/d	n/d	n/d	n/d
C ₂ H ₃ Cl	n/d	n/d	n/d	n/d	200=415	n/d	200=275	n/d	n/d	n/d	n/d	n/d	n/d

n/a – not applicable

n/d – no data

Table 5 Cross Interference Table (pg.5)

Gas	PF ₃	SiH ₄	Si	SiF ₄	SO ₂	C ₄ H ₆ S	C ₄ H ₄ S	C ₆ H ₅ CH ₃	WF ₆	C ₄ H ₆ O ₂	C ₂ H ₃ CL	C ₂ H ₅ SH	C ₆ H ₅ CH ₃
C ₂ H ₃ O	n/d	n/d	n/d	n/d	n/d	n/d	40=45	n/d	n/d	40=200	40=200	n/d	40=55
C ₂ H ₂	n/d	n/d	n/d	n/d	n/d	n/d	340=45	n/d	n/d	340=200	340=200	n/d	340=55
C ₃ H ₃ N	n/d	n/d	n/d	n/d	n/d	n/d	75=45	n/d	n/d	75=200	75=200	n/d	75=55
NH ₃	n/d	n/d	n/d	n/d	5=-0.5	n/d	n/d	n/d	n/d	n/d	n/d	n/d	n/d
AsH ₃	n/d	1=0.56	n/d	n/d	2=0	n/d	n/d	n/d	n/d	n/d	n/d	n/d	n/d
Br ₂	n/d	n/d	n/d	n/d	5=-0.1	n/d	n/d	n/d	n/d	n/d	n/d	n/d	n/d
C ₄ H ₆	n/d	n/d	n/d	n/d	n/d	n/d	170=45	n/d	n/d	170=200	170=200	n/d	170=55
CS ₂	n/d	n/d	n/d	n/d	n/d	n/d	140=45	n/d	n/d	140=200	140=200	n/d	140=55
CO	n/d	n/d	n/d	n/d	5=0	n/d	n/d	n/d	n/d	n/d	n/d	n/d	n/d
Cl ₂	n/d	n/d	n/d	n/d	5=-0.05	n/d	n/d	n/d	n/d	n/d	n/d	n/d	n/d
ClO ₂ (>10ppm)	n/d	n/d	n/d	n/d	5=-0.016	n/d	n/d	n/d	n/d	n/d	n/d	n/d	n/d
ClO ₂ (=10ppm)	n/d	n/d	n/d	n/d	n/d	n/d	n/d	n/d	n/d	n/d	n/d	n/d	n/d
B ₂ H ₆	n/d	1=0.72	n/d	n/d	2=0	n/d	n/d	n/d	n/d	n/d	n/d	n/d	n/d
C ₃ H ₅ OC1	n/d	n/d	n/d	n/d	n/d	n/d	50=45	n/d	n/d	50=200	50=200	n/d	50=55
C ₂ H ₅ OH	n/d	n/d	n/d	n/d	n/d	n/d	180=45	n/d	n/d	180=200	180=200	n/d	180=55
C ₂ H ₅ SH	n/d	n/d	n/d	n/d	5=<3	n/d	n/d	n/d	n/d	n/d	n/d	n/a	n/d
C ₂ H ₄	n/d	n/d	n/d	n/d	n/d	n/d	220=45	n/d	n/d	220=200	220=200	n/d	220=55
C ₂ H ₄ O	n/d	n/d	n/d	n/d	n/d	n/d	275=45	n/d	n/d	275=200	275=200	n/d	275=55
F ₂	n/d	n/d	n/d	n/d	2=0	n/d	n/d	n/d	n/d	n/d	n/d	n/d	n/d
CH ₂ O	n/d	n/d	n/d	n/d	n/d	n/d	330=45	n/d	n/d	330=200	330=200	n/d	330=55
GeH ₄	n/d	1=1	n/d	n/d	2=0	n/d	n/d	n/d	n/d	n/d	n/d	n/d	n/d
N ₂ H ₄	n/d	n/d	n/d	n/d	2=0	n/d	n/d	n/d	n/d	n/d	n/d	n/d	n/d
H ₂ (ppm)	n/d	n/d	n/d	n/d	5=0	n/d	n/d	n/d	n/d	n/d	n/d	n/d	n/d
H ₂ (LEL)	n/d	n/d	n/d	n/d	2=0	n/d	n/d	n/d	n/d	n/d	n/d	n/d	n/d
HBr	n/d	n/d	n/d	n/d	5=2.5	n/d	n/d	n/d	n/d	n/d	n/d	n/d	n/d
HCl	n/d	n/d	n/d	n/d	5=2.5	n/d	n/d	n/d	n/d	n/d	n/d	n/d	n/d
HCN	n/d	n/d	n/d	n/d	2=0	n/d	n/d	n/d	n/d	n/d	n/d	n/d	n/d
HF	yes n/d	n/d	n/d	3=4(theory)	yes n/d	n/d	n/d	n/d	yes n/d	n/d	n/d	n/d	n/d
H ₂ S	n/d	n/d	n/d	n/d	5=<1	n/d	n/d	n/d	n/d	n/d	n/d	3=1	n/d
CH ₃ OH	n/d	n/d	n/d	n/d	n/d	n/d	415=45	n/d	n/d	415=200	415=200	n/d	413=55
CH ₃ SH	n/d	n/d	n/d	n/d	5=<2	n/d	n/d	n/d	n/d	n/d	n/d	2=1	n/d
NO	n/d	n/d	n/d	n/d	5=0	n/d	n/d	n/d	n/d	n/d	n/d	n/d	n/d
NO ₂	n/d	n/d	n/d	n/d	5=-0.025	n/d	n/d	n/d	n/d	n/d	n/d	n/d	n/d
O ₃	n/d	1=0.015	n/d	n/d	2=0	n/d	n/d	n/d	n/d	n/d	n/d	n/d	n/d
COCl ₂	n/d	n/d	n/d	n/d	2=0	n/d	n/d	n/d	n/d	n/d	n/d	n/d	n/d
PH ₃	n/d	1=0.56	n/d	n/d	2=0	n/d	n/d	n/d	n/d	n/d	n/d	n/d	n/d
SiH ₄	n/d	n/a	n/d	n/d	2=0	n/d	n/d	n/d	n/d	n/d	n/d	n/d	n/d
SO ₂	n/d	n/d	n/d	n/d	n/a	n/d	n/d	n/d	n/d	n/d	n/d	n/d	n/d
C ₄ H ₆ O ₂	n/d	n/d	n/d	n/d	n/d	n/d	200=45	n/d	n/d	n/a	200=200	n/d	200=55
C ₂ H ₃ Cl	n/d	n/d	n/d	n/d	n/d	n/d	200=45	n/d	n/d	200=200	n/a	n/d	200=55

n/a – not applicable

n/d – no data

8.4 Spare Parts, Sensor Accessories, Calibration Equipment

Part Number	Spare Parts
921-245400-000	DM-100 Intelligent Transmitter Module (ITM for Toxic Gas Sensors is universal design for all gas types and ranges via label inscription.)
921-345500-025	DM-100 Intelligent Transmitter Module (ITM for O ₂ Sensors)
371-XXXX00-XXX	Replacement Plug-in toxic gas sensor (Refer to Table 3 Sensor Specific Data)
500-005157-100	Model 100 Standard Terminal Board
500-005158-100	Model 100 Display Terminal Board (used with display option)
500-005158-200	Model 100 Display Terminal Board (used with battery option)
345-001560-100	Model 100 Display Assembly
Part Number	Sensor Accessories
613-120000-700	Sensor Splash Guard with integral Cal Port
602-003552-000	100 Series Bottom Housing Assembly (includes DM-100 Splash Guard adapter, O-Ring and Gasket)
602-003552-100	100 Series Bottom Housing Assembly with integral filter (Used in H ₂ S sensor assemblies) (includes DM 100 Splash Guard adapter, O-Ring, Gasket and Filter)
943-002273-000	Harsh Environment Sensor Guard
327-000000-000	Programming Magnet
Part Number	Calibration Accessories
943-000006-132	Threaded Calibration Adapter
943-000000-000	Calibration Wind Guard
943-01747-T05	Calibration Adapter for highly reactive gases
943-050000-132	Span Gas Kit: Includes calibration adapter, span gas humidifier, 500cc/min fixed flow regulator, and carrying case. (Not including gas).
943-050000-HRG	Highly Reactive Gas Span Gas Kit (Used for NH ₃ , Cl ₂ , HCl, HBr, etc.)
See Detcon	Span Gases – various
943-05AM00-000	500 cc/min Fixed Flow Regulator for span gas bottle
Part Number	Optional Accessories
897-850800-010	NEMA 7 Aluminum Condulet Base
897-850400-010	NEMA 7 Aluminum Condulet Solid Cover
897-850500-010	NEMA 7 Aluminum Condulet w/Window Cover
897-850801-316	NEMA 7 316SS Condulet Base
897-850401-316	NEMA 7 316SS Condulet Solid Cover
897-850701-316	NEMA 7 316SS Condulet w/Window Cover
960-202200-000	Condensation prevention packet (For condulet, replace annually)
800-004221-000	Mounting Plate
500-005157-100	Model 100 Standard Terminal Board
500-005158-100	Model 100 Display Terminal Board (used with display option)
500-005158-200	Model 100 Display Terminal Board (used with battery option)
345-001560-100	Model 100 Display Assembly

8.5 Revision Log

Revision	Date	Changes made	Approval
0.0	09/01/2010	Initial Release	LU
0.1	11/08/2010	Update to Cross Interference table to correct wrong value for C2H3CL against CO. Previous value was 1250=100, corrected value is 200=100	LU
0.2	11/17/2010	Added updated table for Jumper descriptions and Jumper settings on DM-100 Terminal Board	LU
0.3	11/30/2010	Corrections to Cross Interference Table, and some spelling	LU
1.0	02/02/2011	Revised ATEX operational guidelines. Updated manual to reflect most current template. Made significant changes due to creation of Wireless DM-100 manual so manuals can complement each other. This includes removing duplicate tables and figures, adding/modifying tables and figures, updating drawings, adding/modifying sections, etc.	BM
1.1	02/15/2011	Added additional notes required by approval agencies.	LU
1.2	04/06/2011	Added references to 100 Series Bottom Housing Assembly with integral filter. Added 100 Series Bottom Housing Assembly with integral filter to spare parts. Modified troubleshooting section to reference use of 100 Series Bottom Housing Assembly with integral filter	BM
1.3	04/13/2011	Add additional guidelines in 2.1 per ATEX requirements.	VR
1.4	06/02/2011	Added "DM-200L Toxic Gas Sensors" on Cover Sheet	LU
1.5	08/01/2011	Added DM-100 intrinsically safe installation notes drawing to back of manual.	LU
2.0	08/17/2011	Updated Terminal Boards, new display	LU

Shipping Address: 3200 A-1 Research Forest Dr., The Woodlands Texas 77381
Mailing Address: P.O. Box 8067, The Woodlands Texas 77387-8067

Phone: 888.367.4286, 281.367.4100 • Fax: 281.292.2860 • www.detcon.com • sales@detcon.com