



Model 140

Gas Detection/Alarm System



Operator's Installation and Instruction Manual

◆ DETCON, Inc.
3200 Research Forest Dr.,
The Woodlands, Texas 77387
Ph.281.367.4100 / Fax 281.298.2868

www.detcon.com

This page left intentionally blank

Table of Contents

1. Description.....	1
2. System Operation.....	2
3. Specifications.....	3
4. Installation.....	4
4.1 Mounting and Cable Penetrations.....	4
4.2 Power and I/O Connections.....	4
4.2.1 AC Power.....	4
4.2.2 DC Power.....	5
4.2.3 Analog 4-20 mA Sensor Input.....	5
4.2.4 Serial Input Gas Sensors.....	7
4.2.5 Serial Polling of the Model 140 Controller.....	8
4.2.6 Relay Outputs.....	8
5. Start-up.....	9
5.1 Power Switch Selections.....	9
5.2 Applying Power.....	9
6. System Configuration.....	10
6.1 Analog/Serial input selection.....	10
6.2 Password Protection.....	10
6.3 Navigating the Menus.....	10
6.3.1 PROG Key:.....	10
6.3.2 “Up Arrow” Key:.....	11
6.3.3 “Down Arrow” Key:.....	11
6.3.4 ENTER and Reset/Ack Key:.....	11
6.4 Main Display Functions.....	11
6.5 User-Interface Menu Functions.....	12
6.5.1 Menu Flow Chart.....	13
6.5.2 Calibration Mode.....	14
6.5.3 Set # of Channels.....	14
6.5.4 Set Channel Range.....	14
6.5.5 Set Channel Type.....	14
6.5.6 Set Channel Alarms.....	15
6.5.7 Set Relay Functions.....	15
6.5.8 Set Date and Time.....	15
6.5.9 Set Modbus Address:.....	16
6.5.10 View TWA and Peak Readings.....	16
6.5.11 View Event Records.....	16
6.5.12 Download History.....	16
6.6 Alarm Test Mode.....	17
6.7 Display Contrast.....	17
7. System Features.....	18
7.1 Modbus Communications.....	18
7.2 Download procedure.....	20
8. Options.....	26
8.1 Option for Battery Back-up Operation.....	26
8.2 Option for 4-20mA Output(s).....	26
8.3 Optional Interface PCB for Remote Display.....	26
8.4 Optional Remote Alarm Reset/Acknowledge Switch.....	27
8.5 Optional Type Z Enclosure Purge Assembly.....	27

9. Troubleshooting Guide.....28

10. Spare Parts.....28

11. Warranty.....28

Appendix A29

 Revision Log.....29

Table of Figures

Figure 1 System Operational Diagram..... 2

Figure 2 Dimensional View of Enclosures.....4

Figure 3 Power Input Schematic5

Figure 4 Mother Board Layout.....6

Figure 5 Control Board Layout7

Figure 6 Power Switch Configuration.....9

Figure 7 Switch SW1 10

Figure 8 Front Panel User Interface 11

Figure 9 Menu Flow Chart..... 13

Figure 10 Serial connection and jumper locations 21

Figure 11 Invoking Hyper Terminal 21

Figure 12 Connection Description 22

Figure 13 Connect to Configuration..... 22

Figure 14 Communications port properties..... 23

Figure 15 Setting up capture 23

Figure 16 Naming Capture File..... 24

Figure 17 Downloading information..... 24

Figure 18 Saving file..... 25

Figure 19 Optional Plug-in Module for 4-20mA output and Remote Display 26

1. Description



Housed in a NEMA 4X weatherproof enclosure, the Detcon Model 140-N4X Gas Detection Alarm System has the capability to handle one 4-20mA sensor input or one RS-485 serial sensor input. The remotely mounted gas sensor (purchased separately) can include any Detcon 4-20mA or RS-485 serial input device such as combustible gas, toxic gas, or oxygen deficiency sensor.

The system displays real time channel information on a backlit LCD. Configuration inputs are completely field-programmable and include channel number, gas type, and gas concentration. It also shows the current Alarm/Fault status via front panel LED indicators. Standard features include recorded history of Time Weighted Average (TWA), Peak readings, and Alarm/Fault/Maintenance Events. Additional features include one-touch Alarm Reset and Alarm Silence (Acknowledge) functions.

The Model 140-N4X has a built-in power supply, giving the user a multitude of power options. It can be powered by either 115/230VAC or 11.5 to 30VDC, and has an optional one-hour battery backup in the event of temporary power loss.

Each control channel has three field programmable alarm relays and one fault relay. The relays have two discrete form "C" contacts and are rated for 5 Amps at 30VDC and 250VAC. The low, high, and high-high alarms have individually field adjustable set points for each gas channel and include the provision to configure the alarm relays in a normally energized (failsafe) or normally de-energized mode of operation. The low, high, high-high and fault alarm relays may also be configured for latching / non-latching and silenceable / non-silenceable operation.

2. System Operation

The Model 140-N4X can be configured for either a 4-20mA sensor input or a RS-485 serial sensor input via a dipswitch selection. The system displays current status information on its LCD display. The information displayed during normal operation includes the gas channel #, current reading and gas type.

Alarm values or fault condition can be field-programmed via the User Interface to cause an assigned relay output to fire, thus triggering an external alarm device. As gas alarm or fault conditions clear, the assigned relay outputs return to their normal states. Relays can be set-up as Energized/De-Energized, Latching/Non-latching and Silenceable/Non-Silenceable. Using the front panel function key, the relay outputs can be silenced or Reset.

The Model 140-N4X-gas detection alarm system has onboard data logging to record all alarm, fault and maintenance events. It also continuously logs the TWA and Peak readings, which can be downloaded for external storage and review. The RS-485 serial output can continuously transmit sensor and alarm data to a PC, PLC, DCS or SCADA where it can be further monitored and logged.

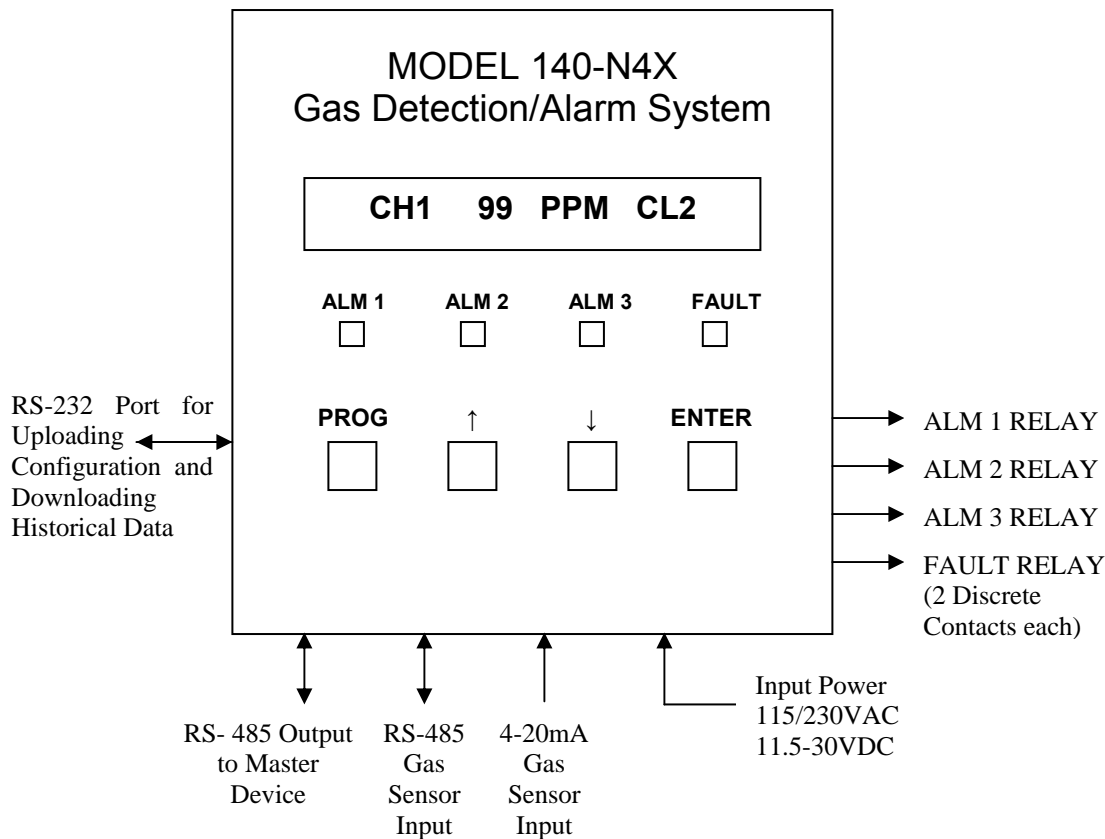

Figure 1 System Operational Diagram

3. Specifications

Electrical	Capacity	1 Input Channel
	Sensor Inputs	Analog 4-20mA or RS-485 Modbus RTU
	Accuracy	± 1% Full Scale Range
	Outputs	Qty 4 Relays: 2 Form C Contacts per relay Rated for 5A @ 30VDC, 5A @ 250VAC RS-485 (Standard) RS-232 for Uploading/Downloading to PC (Standard) 4-20mA (Optional)
	Power Input	115-230VAC 11.5-30VDC
	Power Consumption	Normal: 5 Watts @ 24VDC Maximum: 12 Watts @ 24VDC (Total system power dependent on number of gas sensors & type of gas sensor connected)
Physical	Display	1"x5" Backlit LCD
	Electrical Classification	NEMA 4X
	Dimensions	10"W x 12"H x 6"D
	Operating Temperature Range	-40F to +167F -40C to +75C
	Warranty	One year

4. Installation

4.1 Mounting and Cable Penetrations

Securely mount the Model 140 N4X enclosure per the mounting dimensions provided in Figure 2.

Provide for suitable conduit/cable entries in the bottom of the enclosure. Keep AC power separate from DC signals in conduit connections and runs.

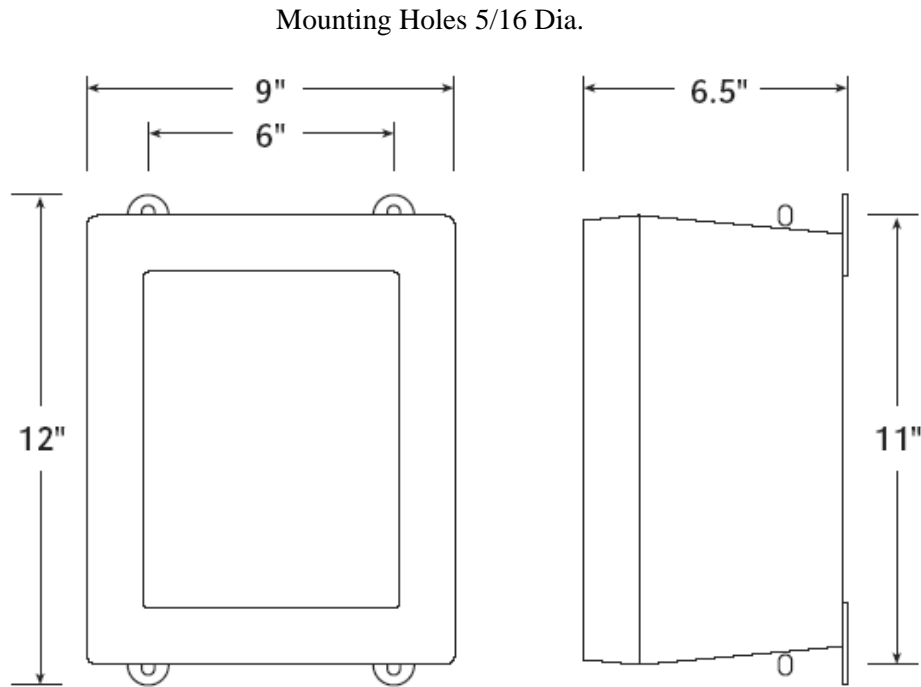

Figure 2 Dimensional View of Enclosures

4.2 Power and I/O Connections

Power and I/O connections are made on the Motherboard PCB, which is mounted on the back of the enclosure. Plug-in male connector terminal blocks are provided for customer wire terminations. This connector style provides for quick disconnect convenience during replacement or servicing. (Refer to Figure 4)

The connections for serial polling of gas sensors and RS-232 PC downloading activities are located at J7 on the Controller PCB. (Refer to Figure 5)

4.2.1 AC Power

Connect the 115 or 230VAC input wiring to the terminals at J2, labeled “AC IN” in Figure 3 and Figure 4.

4.2.2 DC Power

For optional DC power input, connect 11.5-30VDC to the terminals at J8, labeled “DC IN” in Figure 3 and Figure 4. This input can be used for primary power or back-up power in the event of a VAC power failure.

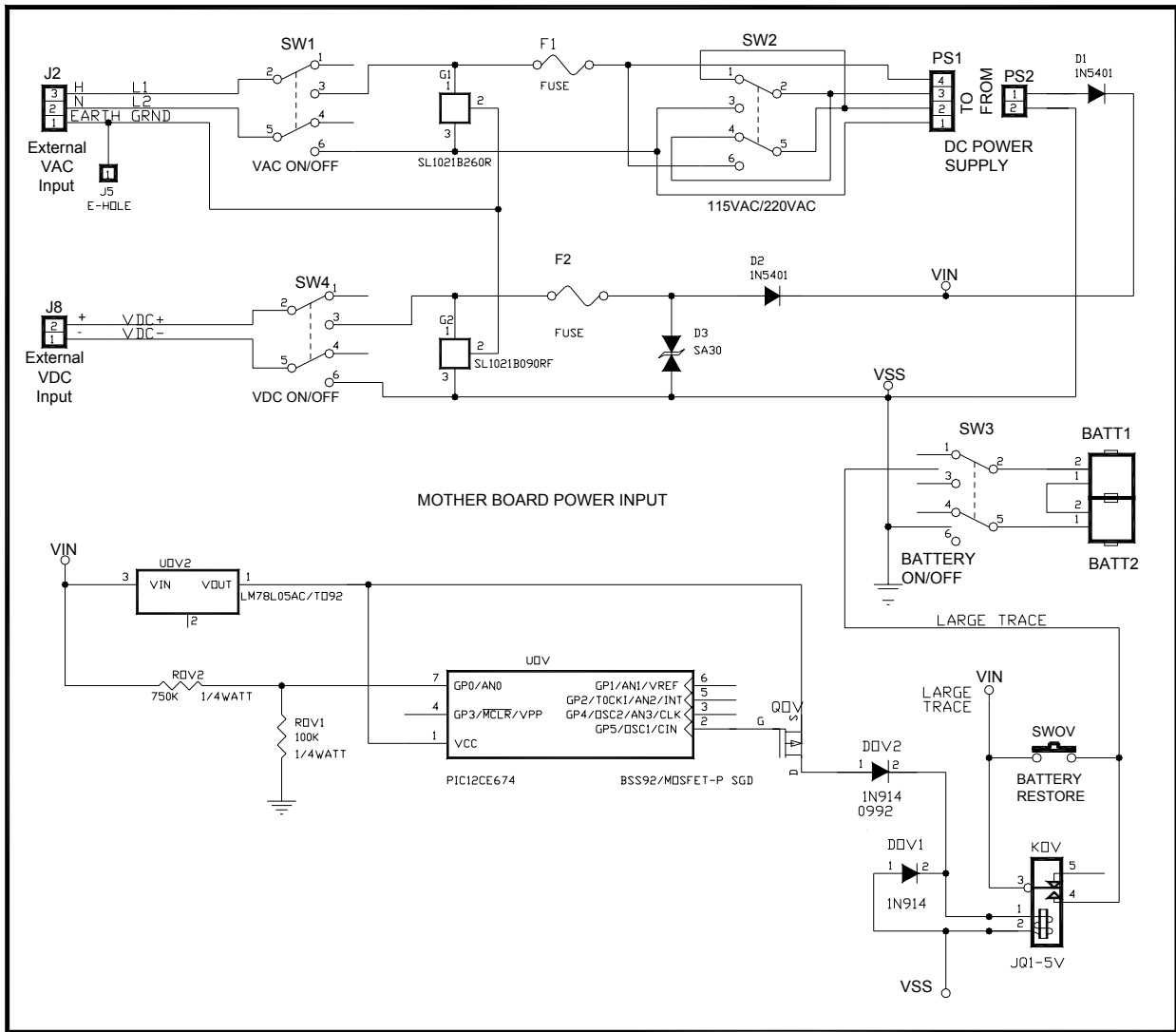

Figure 3 Power Input Schematic

4.2.3 Analog 4-20 mA Sensor Input

Connect 4-20mA type gas sensors to the motherboard at the terminal labeled “CH 1” (J15) in Figure 4. These connections are labeled (+, -, mA). For a 3-wire gas sensor connect to the “+”, “-”, and “mA” terminations. For a 2-wire sensor connect to the “+” and “mA” terminations, refer to the Operators Manual for the gas sensor that is being connected.

Note: Analog sensor polling requires switch SW1-1 on the Control PCB to be set in the “OFF” position. (See Figure 5)

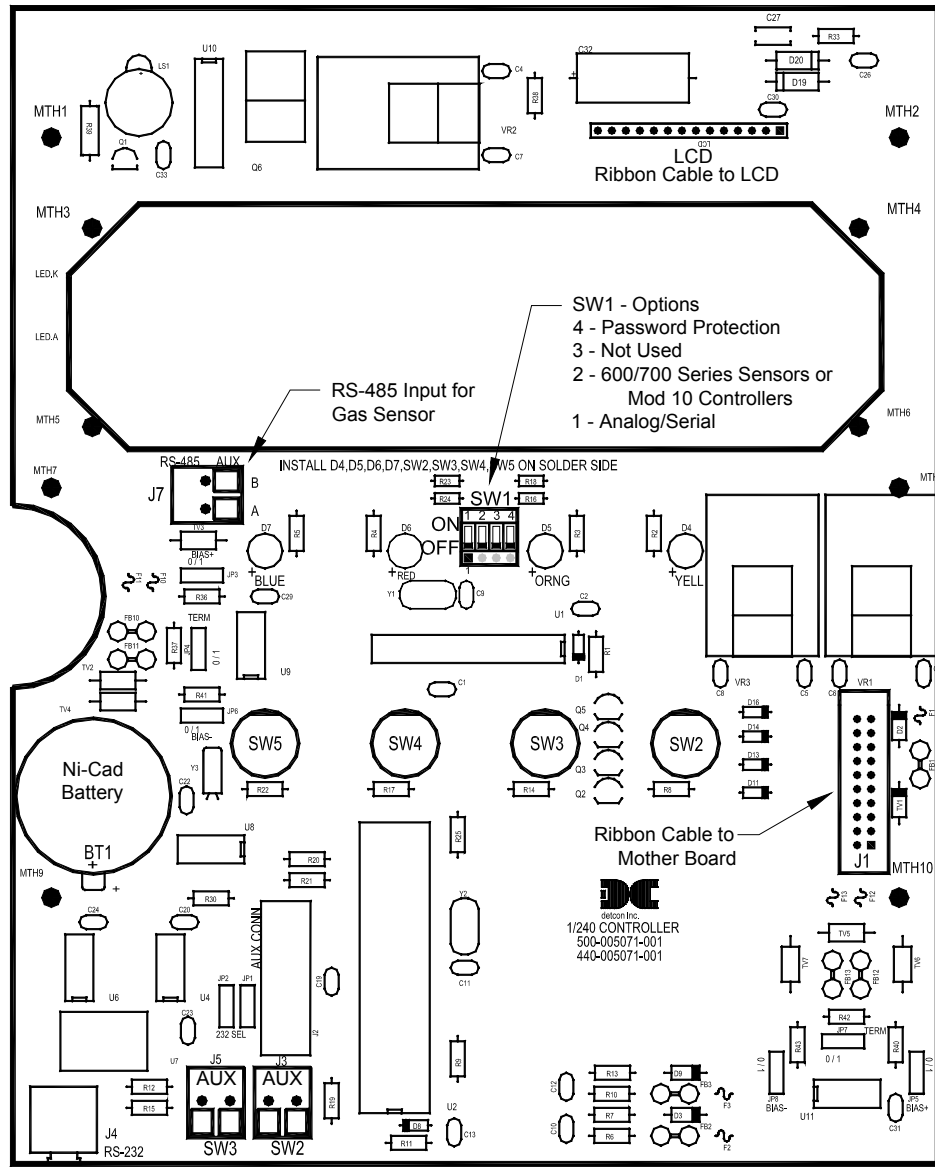

Figure 5 Control Board Layout

4.2.4 Serial Input Gas Sensors

When connecting serial input gas sensors such as the Detcon 600 Series, terminate the 3 conductors from the serial cable in the following manner. Terminate A and B on the Control PCB at connector J7 shown in Figure 5. If applicable, the shield wire can be terminated on the Mother Board at JP1 the RS-485 jumper labeled ‘SHLD TO GND’. (Refer to Figure 4)

Note: Serial sensor polling requires switch SW1-1 on the Control PCB to be in the “ON” position. If polling 600 or 700 Series Sensors, SW1-2 must be in the “OFF” position. If polling Mod 10 Controllers; SW1-2 must be in the “ON” position (See Figure 5).

NOTE: If VDC power for the Detcon Series 600 sensor is not available at the sensor location, then it can be provided via the + and – terminals labeled CH1 on the motherboard. The RS-485 wiring should be a 2 conductor, shielded twisted pair (Belden P/N 9841 is recommended).

4.2.5 Serial Polling of the Model 140 Controller

When polling this device serially, connect the incoming RS-485 wiring to the terminals labeled “RS-485 IN” (J10) on the Motherboard. For connection to the next polled device in the serial loop, connect the RS-485 wiring to J25 labeled “RS-485 OUT”. These terminals are labeled “A”, “B”, and “S” (Shield) for standard RS-485 Modbus™ communication as shown in Figure 4. A jumper on the Motherboard PCB (JP1) provides the option to leave the shield open or tied to earth ground. Choose the appropriate selection for the application.

NOTE: The RS-485 wiring should be a 2 conductor, shielded twisted pair (Belden P/N 9841 is recommended).

4.2.6 Relay Outputs

The standard Model 140 Controller provides four relays. Each relay has 2 Form C contacts. They can be used to fire annunciating devices or as signal inputs to other control devices. Connect to the relay contact terminals of the Motherboard PCB. There are two sets of terminals labeled FAULT, ALARM 1, ALARM 2, and ALARM 3. (Figure 4 – J17-J24.) The relays are double pole double throw (DPDT), which allow more flexibility in the creation of alarm system set-ups. Connections are labeled C (common), NO (normally open) and NC (normally closed).

NOTE: The current ratings of the relay contacts should not be exceeded. (5A @ 30VDC, 5A @ 250VAC)

5. Start-up

NOTE: Before applying power, check and make sure that all the wiring connections and external devices are installed correctly.

NOTE: Applying power with devices hooked up incorrectly may cause damage to the equipment.

5.1 Power Switch Selections

Refer to Figure 6. For AC power, locate the V-SELECT switch (SW2) and select the appropriate voltage setting. If the unit will be powered by AC voltage only, then the VAC power switch (SW1) should be turned to the ON position, and insure the VDC power switch (SW4) is in the OFF position. If DC is used to power the unit, the VDC power switch should be turned to ON and the VAC power switch should be OFF. If the unit is to be powered by AC *and* DC sources simultaneously, then both power switches should be in the ON position. The switches are located on the Motherboard, shown in Figure 4.

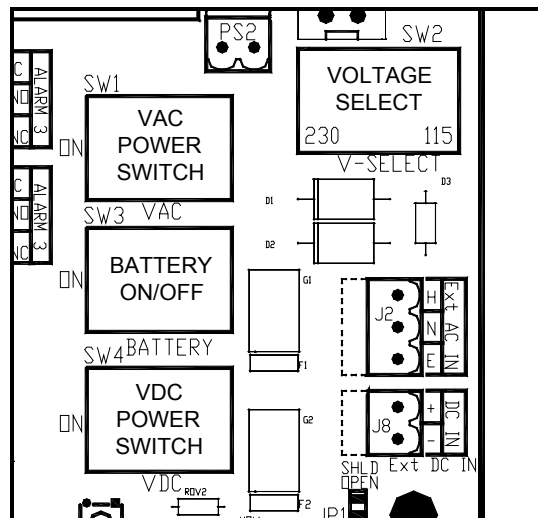

Figure 6 Power Switch Configuration

NOTE: An optional battery back up can be installed in all basic units. A switch to connect or disconnect the battery back up is located on the Motherboard. If the Battery Back-up option is installed this switch will normally be “ON”. See Section 8.1 for details on the Battery Back-up Option.

5.2 Applying Power

Connect power per Section 4.2.

With the AC or DC power source connected, turn the applicable power switches to the ON positions. Verify that the Main Display LCD comes up displaying gas readings on the display. Assuming there is no target gas in the area of the gas sensor, the sensor should read 0 (zero) after a short warm-up period of 1-2 minutes.

NOTE: All alarm relays will be disengaged for the first 1-minute after power-up to provide for an adequate sensor warm-up time.

6. System Configuration

6.1 Analog/Serial input selection

On the Controller PCB, switch SW1 position 1 is used to select between Analog and Serial sensor inputs for the 140 Controller. Switch SW1-1 must be placed in the “ON” position for the unit to accept a Serial RS-485 Modbus™ sensor, and SW1-1 must be placed in the “OFF” position if the sensor is a 4-20mA type sensor (Figure 7). For Serial Input SW1-2 should be “ON” for use with Mod 10 Control Boards, and “OFF” for use with 600 or 700 Series Sensors. SW1-2 has no effect when SW1-1 is set for Analog (“OFF” Position).

NOTE: Incorrect placement switch SW1-1 when using Serial Sensors will cause the unit to display “FAULT” on all channels, and the “FAULT” LED will be lit. Incorrect placement of switch SW1-1 when using Analog Sensors will cause the unit to display “NO-COMM” on all channels, and the “FAULT” LED will be lit. When using Serial Sensors or Mod 10 Controller inputs, ensure that SW1-2 is in the correct position for the type of sensor or controller being polled or the unit will display incorrect readings.

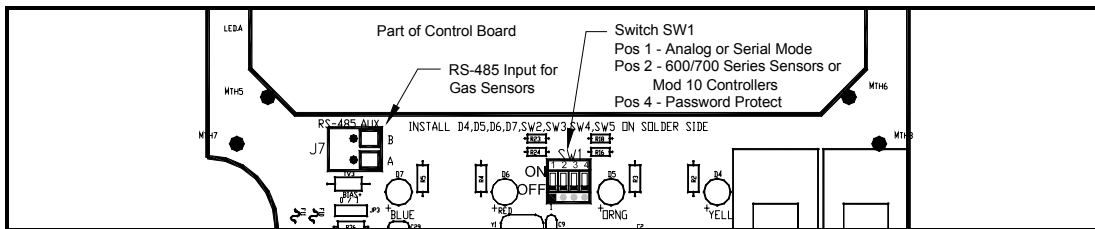

Figure 7 Switch SW1

6.2 Password Protection

Password protection is accomplished via a switch selection on the backside of the Controller PCB (Figure 7 SW1). With Switch SW1 position 4 in the OFF position, the Controller will be in Password Protected mode. In this mode, there is no access to the Menus. The only functionality provided for is the Main Display and the use of the Reset and Acknowledge functions. With SW1-4 in the ON position, Password Protection is turned off and there is complete access to the Menus.

6.3 Navigating the Menus

The menu text is displayed on the backlit LCD and is interfaced via the four function keys located below it. These keys are labeled from left to right: PROG, UP, DOWN, ENTER. The ENTER key is a multiple-use key that also controls the Reset and Acknowledge relay functions. With reference to the Menu Flow Chart (See Figure 9) and the correct function key sequencing, it is easy to learn how to navigate the menus, make changes, and access the logged data.

6.3.1 PROG Key:

From the Main Display, the PROG key enters into the Main Menu. Once inside the Main Menu, the PROG key acts as an “Escape” key that moves backwards in the Menu flow chart.

NOTE: While in Menu Mode there are no updates to gas readings and hence no alarms will take place.

6.3.2 “Up Arrow” Key:

This key moves the user up the Main Menu flow chart. It is also used to change highlighted entries within menu selections in the upward direction.

6.3.3 “Down Arrow” Key:

This key moves the user down the Main Menu flow chart. It is also used to change highlighted entries within menu selections in the downward direction.

6.3.4 ENTER and Reset/Ack Key:

This key has a multiple-use purpose. The ENTER function is used to accept selections within all Menu screens.

The Enter Key is also used to execute the Reset and Acknowledge functions. The Reset function releases all latched relays if pressed after they have cleared the alarm/fault condition. The Acknowledge function will disengage any silenceable relays that are in a currently active state. This is typically used to silence alarm annunciators, once the end-user has assessed the alarm condition.

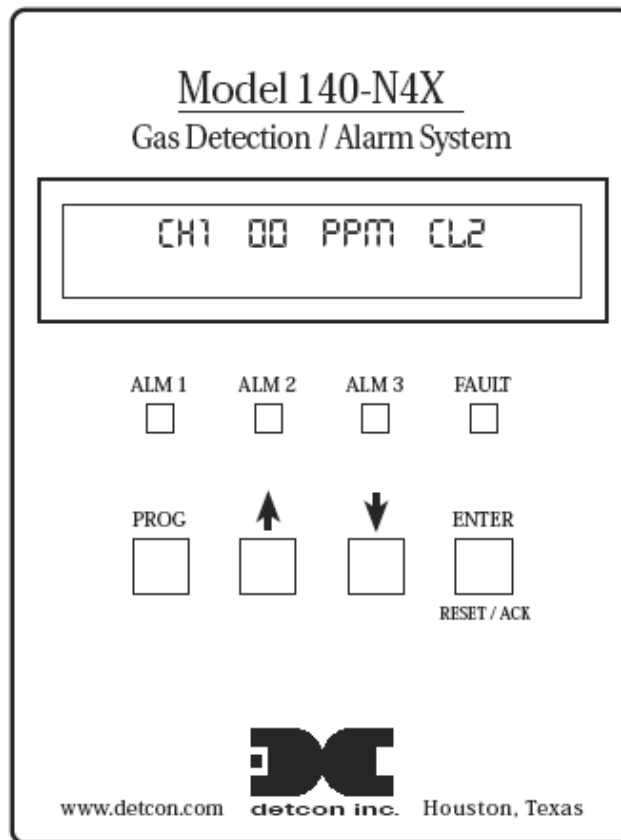

Figure 8 Front Panel User Interface

NOTE: The controller automatically times out of Menu Mode and returns to the Main Display after 1 minute of inactivity.

6.4 Main Display Functions

The Main Display is a 1"x 5" backlit LCD, which has 2 lines by 24 characters. In normal operation "CH # = XX ppm GAS" will be displayed. If any channel is in a gas alarm condition, the "CH#" will change to "ALM". If any gas channels are in Fault, they will display "CH # = IN FAULT". If any channels are in CAL MODE, they will display as "CH # = IN CAL". If any channels are not communicating with sensors set up as serial input sensors, then they will display as "CH # = NO COMM".

NOTE: The LCD has a backlight that will automatically turn off after 30 seconds of inactivity. The LCD backlight will come on automatically as soon as any function key is pressed. This is a feature designed to save on power.

6.5 User-Interface Menu Functions

The User-Interface is conducted via the Model 140-N4X Front Plate shown above in Figure 8. The Menu Flow Chart (Figure 9) is navigated using the function keys described in Figure 8. User-Interface menu activity is conducted via the 1"x5" LCD and the four function keys. Four LED indicators on the front panel show alarm and fault relay status. The LED's represent ALM 1 (green), ALM 2 (amber), ALM 3 (red) and FAULT (blue). There are 13 Main Menu entries and their functional descriptions are discussed below.

6.5.1 Menu Flow Chart

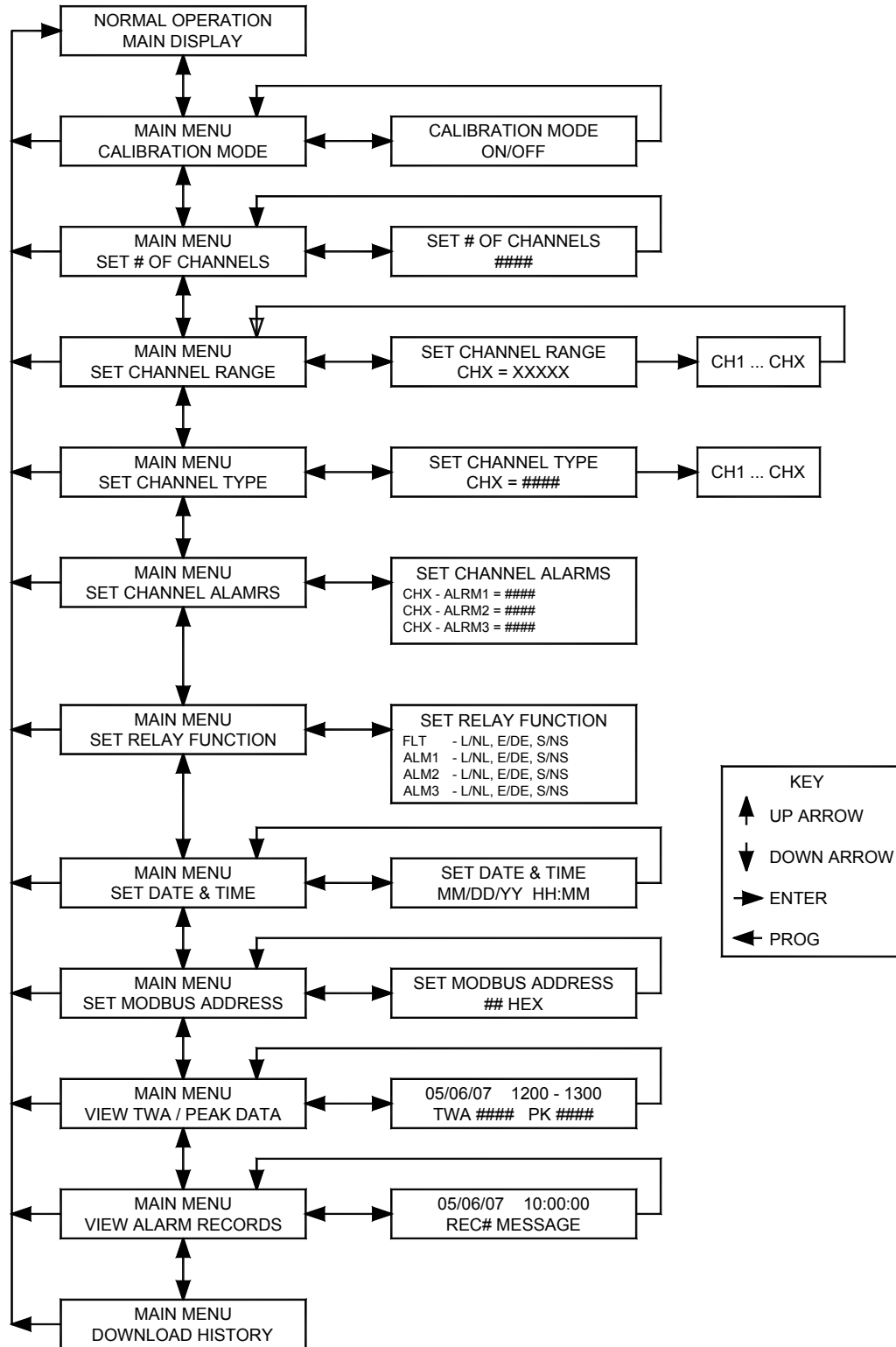

Figure 9 Menu Flow Chart

6.5.2 Calibration Mode

This menu entry allows CALIBRATION MODE to be toggled “ON” or “OFF”. With CALIBRATION MODE on, the attached sensor can be calibrated without triggering any alarms. While the controller is in CALIBRATION MODE, the Main Display will show each channel as “CH # = IN CAL”. The controller will automatically time out of CAL MODE after 60 minutes. The menu appears as:

CALIBRATION MODE:
ON or OFF

NOTE: Some Detcon sensor models (Series 500/600/700) give a 2.0mA signal input when they are being calibrated. The Cal Mode feature is not necessary for these sensor types, and the channel being calibrated will automatically read “IN CAL” while calibration is in process. O2 sensors are usually set as descending alarms, so use of the CALIBRATION MODE: ON is required for them during sensor calibration to avoid unwanted alarm activation.

6.5.3 Set # of Channels

This menu entry allows setting the number of active channels being used. The number of active channels should match the number of sensors being connected to the controller. The menu appears as:

SET # OF CHANNELS:
8

NOTE: the number of activated channels can be less than (but not greater than) the controller’s maximum input capacity.

6.5.4 Set Channel Range

This menu entry allows the selection of the Channel Range for each gas channel input. This is a scrolling list from 1.00 up to 10,000 and covers all of the Detcon gas sensor range possibilities. This menu appears as:

SET CHANNEL RANGE:
CH1 = XX.X

NOTE: If the range is changed, the alarm levels will have to be reset!

6.5.5 Set Channel Type

This menu entry allows the selection of the Channel Type for each gas channel input. The alphanumeric string should encompass the units of measure followed by the chemical formula. (I.E. “ppm H2S” or “% LEL”.) Use the up and down arrows to find the appropriate alphanumeric selection and then use the ENTER button to select it. Enter the character string, as it is expected to be displayed on the Main Display.

NOTE: The character entry for a “space” is required and is available in the alphanumeric choices. All character positions must have an entry, including “spaces” for unused characters at the end of the string. This menu appears as:

SET CHANNEL TYPE:
CH1 = (PPM_H2S__)

6.5.6 Set Channel Alarms

This menu entry allows the selection of the Channel Alarms for each gas channel input. These represent the alarm level set points. These set points can be entered in 5% increments of the full-scale range selected for that channel. Selection of ascending (right arrow) or descending (left arrow) alarms is also made in this menu selection. This menu appears as:

SET CHANNEL ALARMS:
CH1 - ALM1 = X.X →

Each gas channel has the capability to set up to 3 alarms (ALM1, ALM2, and ALM3).

NOTE: If there is no intention of using a gas alarm relay, a setting of 0.00 (zero) will make it inactive.

NOTE: Any channels that are in alarm will display “ALM” instead of “CH#” on the Main Display.

NOTE: If the channel range is changed, then the alarm set points must be re-entered!

6.5.7 Set Relay Functions

This menu entry is used for relay function set-up. This unit has four relays. Three relays are used for ALM1, ALM2 and ALM3 and the fourth relay is used for the FAULT condition. All four relays must be set-up to account for the following 3 settings: latching or non-latching, energized or de-energized, and silenceable or non-silenceable. This is accomplished by toggling the selection entries. The menu appears as shown below. The menu guides the user through the required set-up for all the relay parameters shown in the order below.

SET RELAY FUNCTION:
FLT - LATCHING/NON-LATCHING

FLT - LATCHING/NON-LATCHING		ALM1 - LATCHING/NON-LATCHING	
FLT - ENERGIZED/NON-ENERGIZED	→	ALM1 - ENERGIZED/NON-ENERGIZED	→
FLT - SILENCE/NO-SILENCE		ALM1 - SILENCE/NO-SILENCE	
ALM2 - LATCHING/NON-LATCHING		ALM3 - LATCHING/NON-LATCHING	
ALM2 - ENERGIZED/NON-ENERGIZED	→	ALM3 - ENERGIZED/NON-ENERGIZED	
ALM2 - SILENCE/NO-SILENCE		ALM3 - SILENCE/NO-SILENCE	

NOTE: It is generally recommended to set the FAULT relay as energized so that it will trip upon loss of power.

NOTE: The FAULT condition is assigned to the FAULT relay as a standard. It cannot be disengaged in the configuration of the controller. The Main Display will show FAULT for any channel that is in FAULT.

6.5.8 Set Date and Time

This menu entry allows for the correct entry of the current date and time. The menu appears as:

SET DATE AND TIME:
01/26/04_14:56:07

6.5.9 Set Modbus Address:

This menu entry allows for the setting of the serial address of this controller when it is to be polled by another master device via RS485 Modbus RTU. This should be set in hexadecimal format.

SET MODBUS ADDRESS:
01

6.5.10 View TWA and Peak Readings

This menu entry is used to view the recorded TWA and Peak readings for the different gas channels. This data can be viewed on the screen or can be downloaded via the RS232 port to a PC for graphical presentation. Refer to Section 7.2 on instruction for using the downloading software provided with this controller.

05/05/04 09:00 0001
CH1 TWA XX PK XX

This data is recorded and formatted for display. It will report the date (05/05/04), time (09:00), record # (0001), CH#, TWA and Peak reading as shown above.

6.5.11 View Event Records

This menu entry is used to view the recorded and saved Alarm, Fault and Maintenance records for the different gas channels. This data can be viewed on the screen or can be downloaded via the RS-232 port to a PC for graphical presentation. Refer to Section 7.2 on instruction for using the downloading software provided with this controller.

05/06/04 09:00
0000 CH1 ALM1 ON

The data is formatted for display. It will report the date, time, record #, CH#, Event type and Event status. All events will be logged with their start and stop times in the order that they occur.

6.5.12 Download History

The menu item allows downloading the units' history to a PC. Continuous data for TWA and Peak readings are stored at 1-hour increments in permanent memory for retrieval. All Event Records are stored only as they occur. The duration of the recorded storage is 1 month for the TWA readings, Peak readings, and Event Records. Refer to Section 7.2 for complete procedure.

DOWNLOAD HISTORY

6.6 Alarm Test Mode

Alarm conditions can be simulated and relay contacts can be verified by use of this special software feature. To activate the Alarm Test Mode, hold the ▼ (Down) key for 5 seconds while in the Main Display Mode. After holding the ▼ (Down) key for 5 seconds there will be an audible “Chirp”, then all active gas channels will display “CH# 00 TESTING”. The readings will increment up at 1% full scale per second. When full scale is reached the readings will decrement to 0. The unit will continue to cycle until Alarm Test Mode is exited. As the readings cross their respective alarm set points, the relays will fire according to their configuration. To exit Alarm Test Mode, hold the ▼ (Down) key for 5 seconds and the unit will return to Normal Operation.

6.7 Display Contrast

The display contrast can be adjusted by pressing the “up-arrow” key when the unit is in Normal Operation. Pressing the “up-arrow” key repeatedly will cause the display contrast to change in steps to the minimum limit; the contrast will then ‘roll’ back to the maximum limit and start the cycle over. When the correct contrast level is obtained stop pressing the “up-arrow” key and the contrast will remain at that level.

7. System Features

7.1 Modbus Communications

The model 140 controllers feature a Modbus compatible communications protocol and are addressable by a PLC, PC/HMI, DCS, or other Modbus RTU master polling device. Communications is accomplished by two wire half duplex RS-485, 9600 baud, 8 data bits, 1 stop bit, no parity, through the controllers secondary port. Wiring should be brought directly to J10 located on the motherboard.

A Modbus™ RTU master device up to 4000 feet away can theoretically poll up to 64 different controllers. This number may not be realistic in harsh environments where noise and/or wiring conditions would make it impractical to place so many devices on the same pair of wires. If a multi-point system is being utilized, each controller must be set to a different device address.

Modbus™ Register Detail:

Code 03 - Read Holding Registers, is the only code supported by the 140 controller.

Register #

40000 Channel 1 Reading

40002 Fault Status Bits

High Byte

Bit 7	Not Used
Bit 6	Not Used
Bit 5	Not Used
Bit 4	Not Used
Bit 3	Not Used
Bit 2	Not Used
Bit 1	Not Used
Bit 0	Not Used

Low Byte

Bit 7	Not Used	
Bit 6	Not Used	
Bit 5	Not Used	
Bit 4	Not Used	
Bit 3	Not Used	
Bit 2	Not Used	
Bit 1	Not Used	
Bit 0	1 = Channel 1 Fault	0 = Channel 1 no Fault

40003 Alarm 1 Status Bits

High Byte

Bit 7	Not Used
Bit 6	Not Used
Bit 5	Not Used
Bit 4	Not Used
Bit 3	Not Used
Bit 2	Not Used
Bit 1	Not Used
Bit 0	Not Used

Low Byte

Bit 7	Not Used
-------	----------

Bit 6	Not Used	
Bit 5	Not Used	
Bit 4	Not Used	
Bit 3	Not Used	
Bit 2	Not Used	
Bit 1	Not Used	
Bit 0	1 = Channel 1 Alarm 1	0 = Channel 1 no Alarm 1

40004 Alarm 2 Status Bits

High Byte

Bit 7	Not Used
Bit 6	Not Used
Bit 5	Not Used
Bit 4	Not Used
Bit 3	Not Used
Bit 2	Not Used
Bit 1	Not Used
Bit 0	Not Used

Low Byte

Bit 7	Not Used	
Bit 6	Not Used	
Bit 5	Not Used	
Bit 4	Not Used	
Bit 3	Not Used	
Bit 2	Not Used	
Bit 1	Not Used	
Bit 0	1 = Channel 1 Alarm 2	0 = Channel 1 no Alarm 2

40005 Alarm 3 Status Bits

High Byte

Bit 7	Not Used
Bit 6	Not Used
Bit 5	Not Used
Bit 4	Not Used
Bit 3	Not Used
Bit 2	Not Used
Bit 1	Not Used
Bit 0	Not Used

Low Byte

Bit 7	Not Used	
Bit 6	Not Used	
Bit 5	Not Used	
Bit 4	Not Used	
Bit 3	Not Used	
Bit 2	Not Used	
Bit 1	Not Used	
Bit 0	1 = Channel 1 Alarm 3	0 = Channel 1 no Alarm 3

40006 Cal Status Bits

High Byte

Bit 7	Not Used
Bit 6	Not Used
Bit 5	Not Used
Bit 4	Not Used

Bit 3	Not Used	
Bit 2	Not Used	
Bit 1	Not Used	
Bit 0	Not Used	
Low Byte		
Bit 7	Not Used	
Bit 6	Not Used	
Bit 5	Not Used	
Bit 4	Not Used	
Bit 3	Not Used	
Bit 2	Not Used	
Bit 1	Not Used	
Bit 0	1 = Channel 1 Cal	0 = Channel 1 no Cal

7.2 Download procedure.

The Model 140-N4X Gas Detection Alarm System has very capable features in the area of data logging and event reporting. Continuous data for TWA and Peak readings are stored at 1-hour increments in permanent memory for retrieval. All Event Records are stored only as they occur. The duration of the recorded storage is 1 month for the TWA readings, Peak readings, and Event Records.

This data can be downloaded to an external PC. The downloaded data can be exported into a Microsoft Excel spreadsheet for graphing purposes. The procedure requires a computer with windows Hyper Terminal, a serial port, and Detcon connections cable part number 980-26117. If the computer does not have a serial port, a USB to serial adapter will also be required. USB to serial adapters may be purchased from many retail electronics stores.

NOTE: The download feature will only work with the following X40 controller hardware. This number is printed in white on the back of the controller PCB. The controller firmware *must* be a version that supports this feature. The controller firmware revision can be checked by cycling power to the controller and observing the LCD display.

<u>Hardware Number</u>	<u>Firmware Version</u>
440-005071-001	1.23 or higher.
440-005072-001	1.23 or higher.
440-005073-001	1.18 or higher.

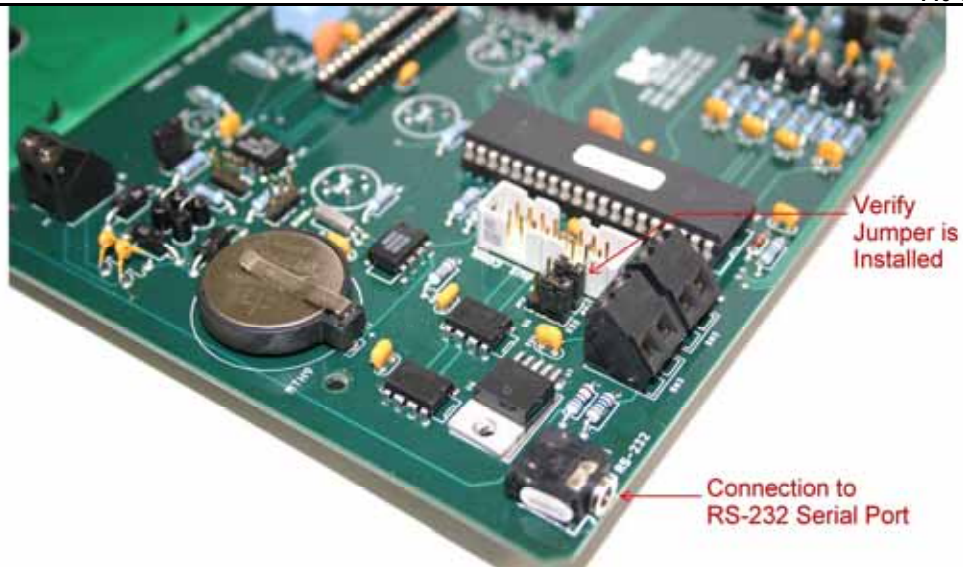

Figure 10 Serial connection and jumper locations

Make the connection from the Model X40 controller to your PC (COM1) using the supplied cable. The controller’s 1/8” jack connection is located on the bottom of the PCB.

From the Start menu, select Programs> Accessories> Communications> Hyper Terminal.



Figure 11 Invoking Hyper Terminal

Hyper Terminal will open with the following Connection Description Dialog box. Type “X40 Download” as the name for the connection and click ‘OK’.



Figure 12 Connection Description

The “Connect To” Dialog box will appear. For Connect using: choose COM1 and Click OK.



Figure 13 Connect to Configuration

The COM1 Properties Dialog box will appear. Insure the settings are:
 Bits per second: 9600
 Data bits: 8
 Parity: None
 Stop bits: 1
 Flow control: None
 Click OK.

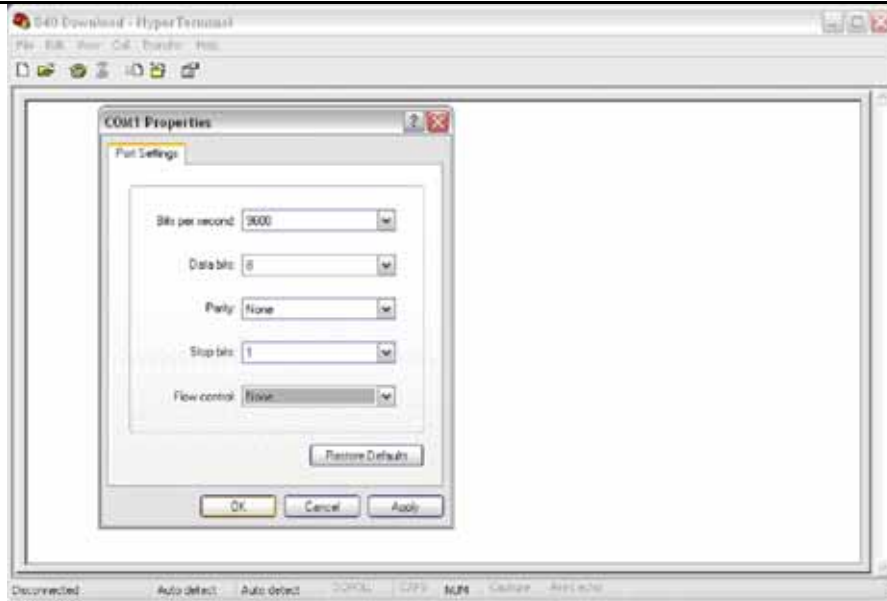

Figure 14 Communications port properties

From the main menu Select: Transfer> Capture Text.

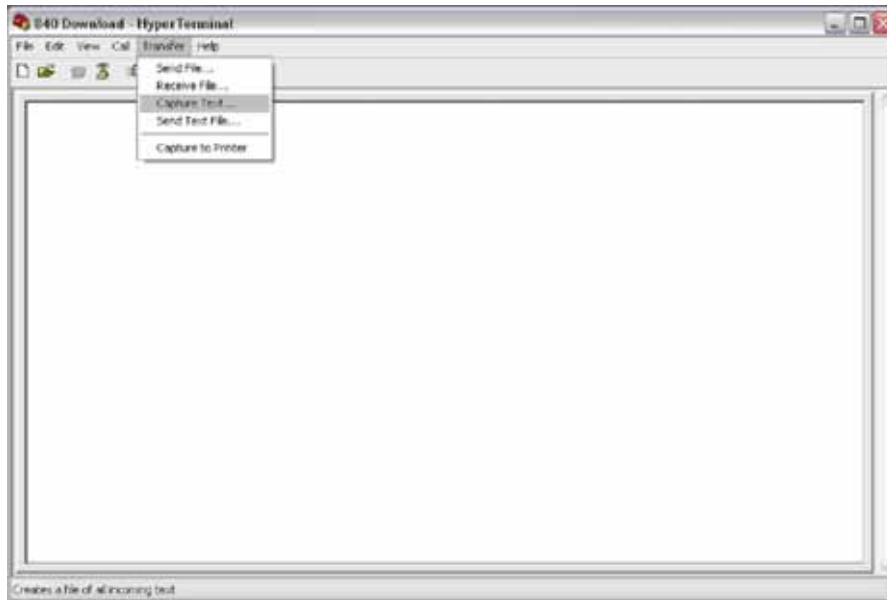

Figure 15 Setting up capture

Select a Name and location where the downloaded data is to be saved, and click “Start”. The file will be saved as a text file and the file extension of *.txt should be used.

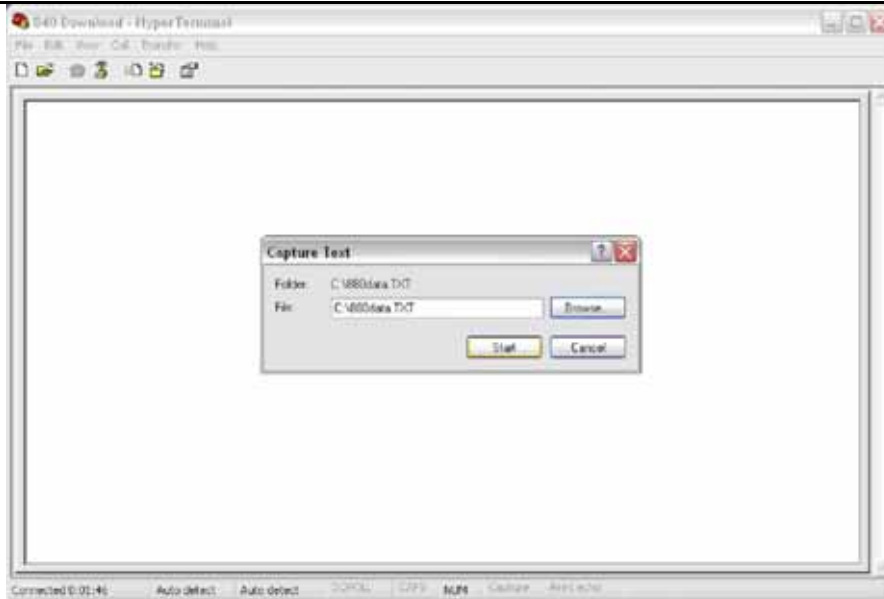

Figure 16 Naming Capture File

On the X40 controller, enter the main menu. Scroll down to “MAIN MENU:” “DOWNLOAD HISTORY”. Press the Enter button. The display should read “STREAMING DATA.....”. Once the controller has finished sending data to the PC, it will return to the main menu. If no buttons are pressed, the controller will return to normal operation.

If the download was successful the display should look similar to figure 7 on the PC.

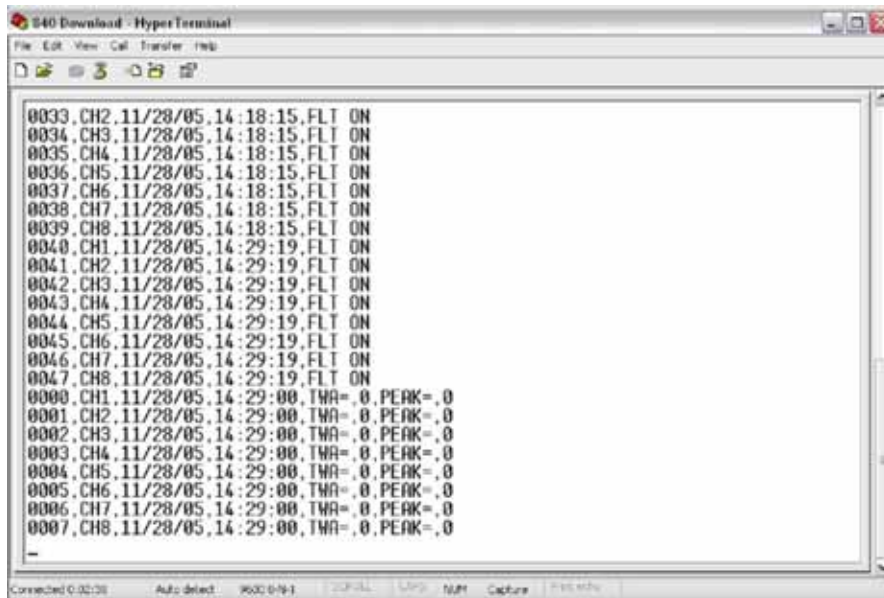

Figure 17 Downloading information

Once the data stream from the controller has been verified as stopped, select: Transfer> Capture Text> Stop from the main menu.

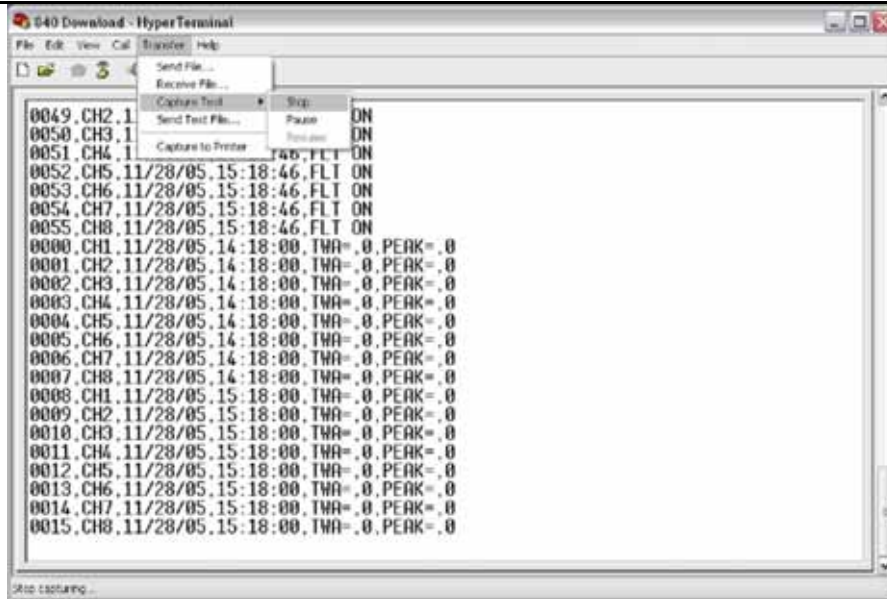

Figure 18 Saving file

Disconnect the controller from the PC.

The raw data from the controller is now stored in the file and location selected, and available for the user to use as desired.

8. Options

8.1 Option for Battery Back-up Operation

This option provides a nominal 1-hour of battery back-up power to the Gas Detection Alarm System. The battery back-up system consists of two 12VDC / 0.8 Amp-hour batteries in series, along with the requisite low voltage cut-off circuitry. The batteries may be isolated during exchange or while in long-term storage by using the battery disconnect switch shown in Figure 4. The low voltage cut-off circuit is designed to disconnect the battery supply if the voltage is drained below 20VDC. This is for battery protection purposes. There is a battery restore switch on the Motherboard PCB, which must be pressed after the low voltage cut-off is triggered. This is only necessary if the unit is going to be restored under battery power. It is not necessary if restored under VAC power.

8.2 Option for 4-20mA Output(s)

An optional PCB that plugs into the controller board is available for 4-20mA outputs. This PCB has four channels of 4-20mA output. Only the first channel is used with the 140 Control Unit. See Figure 19 for the correct installation and wire terminations for this feature.

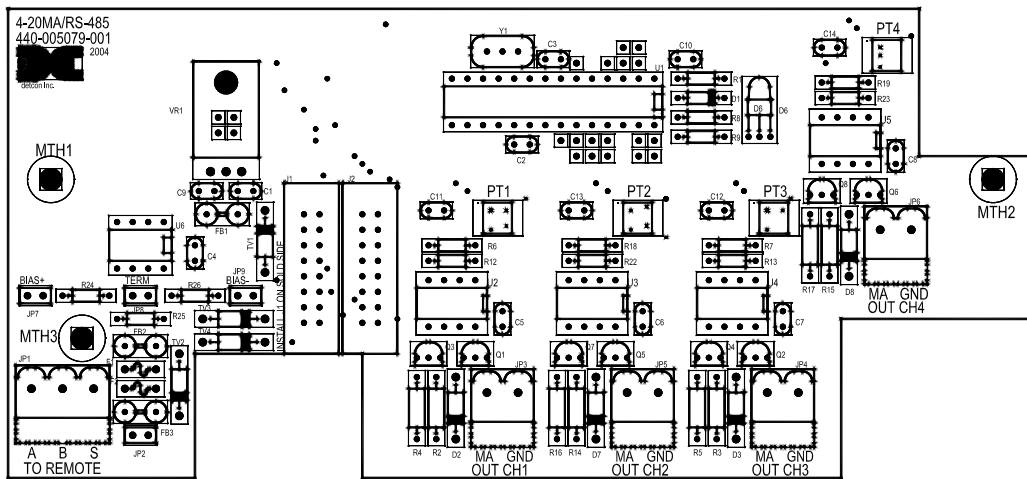

Figure 19 Optional Plug-in Module for 4-20mA output and Remote Display

8.3 Optional Interface PCB for Remote Display

The same PCB that provides the 4-20mA output option is also used as the required interface for the Remote Display option (Figure 19). The RS-485 terminal block labeled ‘A B S - TO REMOTE’ is used to connect to the Remote Display. The actual Remote Display hardware is ordered separately as a Model 140-RD Read-Only-Remote display.

8.4 Optional Remote Alarm Reset/Acknowledge Switch

Model X40 controllers are designed for an optional Remote Alarm Reset/Acknowledge Switch. This enables the user to reset or acknowledge alarms without having to open the NEMA 4X enclosure. The Reset Switch is a momentary type switch and will typically be mounted on the bottom or side of the NEMA 4X enclosure. Toggle the momentary switch to execute the reset/acknowledge function.

The Remote Alarm Reset/Acknowledge Switch is wired to the terminal block labeled SW3 on the backside of the Main Controller PCB. Refer to Figure 5.

8.5 Optional Type Z Enclosure Purge Assembly

Model X40 controllers are available with an optional, externally mounted, Model 1001A Z-Purge system. This purge assembly achieves a Class 1, Division 2, Group CD area classification. The Type Z-Purge assembly is installed on the X40 Controller at the Detcon factory.

The Z-Purge option is factory wired to automatically removed AC power from the controller if there is a loss of pressure. The Z-Purge is not wired to remove DC Power or battery backup power from the unit. It is the responsibility of the user to manually shut off all power sources if pressure is lost or the X40 Controller enclosure is opened.

The Type Z purge option includes a factory installed bypass switch that can be used to continue operation of the Model X40 Controller even when the NEMA 4X enclosure is opened and the purge system pressure is lost. The bypass switch can be toggled between Bypass and Normal, where in the Bypass mode the purge protection and Class 1 Div 2 area classification is lost.

NOTE1: The Z-Purge option is factory wired to automatically removed AC power from the controller if there is a loss of pressure. The Z-Purge is not wired to remove DC Power or battery backup power from the unit. It is the responsibility of the user to manually shut off all power sources if pressure is lost or the X40 Controller enclosure is opened.

NOTE2: Use of the purge bypass switch invalidates the Class 1 Div 2 area classification and should not be done without proper authorization. When purge pressure is lost, Class 1 Div 2 area classification is lost regardless.

The instruction manual for the Model 1001A Type Z purge system is supplied separately. Refer to this manual for details on purge supply requirements.

9. Troubleshooting Guide

Problem	Potential Fix
Unit will not Power Up	→ Check for correct AC or DC voltage selection. → Check for correct VAC and VDC powering configuration.
Relays are not firing	→ Check that the alarm relays are configured properly
Program Locks up or showing erroneous information	→ Re-initialize unit. By pressing the Program Key for 3-5 seconds during power-up recycle (Screen will display “Restoring Defaults”) → Re-enter all Channel and alarm information.
Alarms on constantly	→ Insure that no channels are set to ascending or descending incorrectly.
Alarm Firing causes unit to ‘Lock-Up’	→ Check that Alarm Annunciators current draw does not exceed the on-board Power Supply limitations. Replace with external Power Supply if necessary.
Analog Sensors reading “FAULT”	→ SW1-4 must be set to “OFF” position.
Serial Sensors reading “NO-COMM”	→ SW1-4 must be set to “ON” position.
Serial Sensors display incorrect readings	→ SW1-2 Must be set to the correct position for the sensor or Mod 10 Controller (“ON” for Mod 10 Controllers, “OFF” for 600/700 Series Sensors)
Contact the Detcon Service Department for further troubleshooting assistance at 281-367-4100.	

10. Spare Parts

500-005075-001	Motherboard PCB
500-005071-LCD	Controller Board PCB W/ LCD Display
345-RC2002-000	Replacement LCD module
360-500001-000	Replaceable Power Supply with cables
500-005079-000	4-20mA output/RS-485 output PCB (Optional)
340-120800-000	12 VDC Batteries (Optional)
360-BR2330	Date/Time Clock NICAD Battery

11. Warranty

Detcon, Inc., as the manufacturer, warrants under intended normal use each new Model 140-N4X controller to be free from defects in material and workmanship for a period of one year from the date of shipment to the original purchaser. Should the controller fail to perform in accordance with published specifications within the warranty period, return to Detcon, Inc., for necessary repairs or replacement. All warranties and service policies are FOB the Detcon facility located in The Woodlands, Texas.

Appendix A

Revision Log

Revision	Date	Changes made	Approval
1.7	01/12/2009	Correction to Password Protection switch direction Section 6.2	BM
1.8	11/1/2010	Correction to Note regarding use of Calibration Mode when sensors in calibration, Section 6.5.2	LU

Shipping Address: 3200 A-1 Research Forest Dr., The Woodlands Texas 77381
Mailing Address: P.O. Box 8067, The Woodlands Texas 77387-8067
Phone: 888.367.4286, 281.367.4100 • Fax: 281.292.2860 • www.detcon.com • sales@detcon.com