



MODEL TP-624C

HYDROGEN SULFIDE SENSOR

ISO 9001:2008
Certified

888-367-4286
713-559-9200
fax 281-292-2860
www.detcon.com
sales@detcon.com

SPECIFICATIONS

Sensor Type

Solid State Metal Oxide Semiconductor

Measurement Range

0-20 ppm, 0-50 ppm, 0-100 ppm
Hydrogen Sulfide

Accuracy/Repeatability

±10% of reading or ±2 ppm (greater of)

Response/Clearing Time

T50 <30 seconds
T80 <60 seconds

Operating Temperature Range

-40°F to +167°F; -40°C to +75°C

Operating Humidity Range

15-100% RH non-condensing

Outputs

Linear 4-20 mA DC
RS-485 Modbus™
3 Relays (alarm 1, alarm 2, & fault)
Contacts rated 5 amps

Input Voltage

22-28 VDC

Power Consumption

<3 watts @ 24 VDC

Electrical Classification

Explosion proof
Class I, Division 1, Groups B, C, D

Safety Approvals

CSA and UL Approved

Sensor Life/Warranty

Sensor: 10 year conditional warranty
Transmitter: 2 year warranty

DIMENSIONS

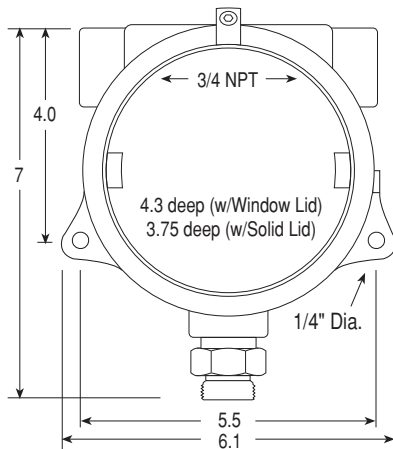

Splashguard 2"H x 2"Dia.

Solid State MOS

MicroSafe™ Intelligent Sensor

DESCRIPTION

Detcon Model TP-624C Hydrogen Sulfide sensors are non-intrusive "Smart" sensors designed to detect and monitor H2S in air over the range of 0-100 ppm. The sensor assembly consists of a proprietary solid state metal oxide semiconductor sensor in a stainless steel housing that includes a splashguard with integral cal port, a plug-in control transmitter circuit, a base connector board and an explosion proof enclosure.



FEATURES

- ▶ CSA and UL Approved: Class I, Division 1, Groups B, C, & D
- ▶ Compatible with PLCs, SCADA, DCS, via 0-20 mA, and/or RS-485, and/or alarm relays
- ▶ Sensor status and parameters accessible via RS-485 (Modbus™)
- ▶ Menu programmable relays standard (two alarms plus fault)
- ▶ Simple menu driven calibration - less than 3 minutes
- ▶ LED display and LED indicators for FAULT and CAL status
- ▶ Plug-in field-replaceable transmitter
- ▶ Response Characteristics similar to that of electrochemical sensors: T-50 <30 sec., T-80 <60 sec.
- ▶ VERY wide operating temperature range: -40°C to +75°C
- ▶ 10 year conditional sensor warranty
- ▶ Direct response constant temperature control
- ▶ Withstands exposure to high range concentrations of H2S and other acid gases
- ▶ Impervious to high moisture environments in both powered and non-powered mode

ORDER GUIDE

PN 966-014520-100 Model TP-624C in Aluminum Junction Box
PN 966-01452B-100 Model TP-624C-316SS in Stainless Steel Junction Box

www.detcon.com