



MODEL FP-624HT

COMBUSTIBLE GAS SENSOR (HIGH TEMPERATURE VERSION)

ISO 9001:2008
Certified

888-367-4286
713-559-9200
fax 281-292-2860
www.detcon.com
sales@detcon.com

SPECIFICATIONS

Sensor Type

Matched-pair catalytic bead

Measurement Range

0-100% LEL (lower explosive limit)
Combustible Gas

Accuracy/Repeatability

±3% 0-50% LEL
±5% 50-100% LEL

Response/Clearing Time

T50 <10 seconds
T90 <30 seconds

Zero Drift

<5% per year

Operating Temperature Range

Sensor: -40°F to +300°F; -40°C to +150°C
Transmitter: -40°F to +167°F; -40°C to +75°C

Operating Humidity Range

0-99% RH non-condensing

Outputs

Linear 4-20 mA DC
RS-485 Modbus™
3 Relays (alarm 1, alarm 2, & fault)
Contacts rated 5 amps

Input Voltage

22.5-28 VDC

Power Consumption

3.1 watts @ 24 VDC

Electrical Classification

Explosion proof
Class I, Division 1, Groups B, C, D

Sensor Life/Warranty

Sensor: 1 year warranty
Transmitter: 2 year warranty

DIMENSIONS

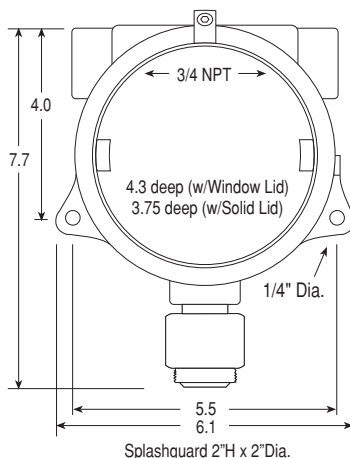

Transmitter



Sensor



Matched Pair Catalytic Bead

MicroSafe Intelligent Sensor

DESCRIPTION

Detcon Model FP-624HT sensors are non-intrusive "Smart" sensors designed to detect and monitor combustible gas in air over the range of 0-100% LEL (lower explosive limit). The sensor assembly consists of a matched-pair catalytic bead sensor in a stainless steel housing that includes a splashguard with integral cal port, a plug-in control transmitter circuit, a base connector board and an explosion proof enclosure. This sensor assembly is specifically designed for high temperature applications wherein the sensor can be mounted in high temperature areas while the transmitter is installed outside the area using a sensor separation kit.

FEATURES

- High Temperature sensor head rated for 150°C operation
- Compatible with PLCs, SCADA, DCS, via 4-20 mA, and/or RS-485, and/or alarm relays
- Sensor status and parameters accessible via RS-485 (Modbus™)
- Menu programmable relays standard (two alarms plus fault)
- Simple menu driven calibration - takes less than 3 minutes
- LED display and LED indicators for FAULT, ALARM 1, ALARM 2 and CAL status
- Plug-in field-replaceable transmitter and sensor
- Long sensor life expectancy: averaging longer than five years in harsh offshore drilling/production environment
- High resistance to poisons such as sulfides, chlorides, silicon-based contaminants etc.
- Low power consumption (less than 3.5 watts versus 8+ watts on competitive brands)

ORDER GUIDE

PN 966-534520-100 Model FP-624HT in Aluminum Junction Box
PN 966-53452B-100 Model FP-624HT-316SS in Stainless Steel Junction Box

www.detcon.com