



MODEL IR-540

CARBON DIOXIDE SENSOR

ISO 9001:2008
Certified

888-367-4286
713-559-9200
fax 281-292-2860
www.detcon.com
sales@detcon.com

SPECIFICATIONS

Sensor Type

Non-dispersive Infrared Optical (NDIR)

Measurement Range

0 - 0.3%/0 - 1%/0 - 3%/0 - 5% by volume

Accuracy/Repeatability

±5% full scale

Response/Clearing Time

T50 <15 seconds

T90 <40 seconds

Zero Drift

<0.05% per year

Operating Temperature Range

-40°F to +167°F; -40°C to +75°C

Operating Humidity Range

0-99% RH non-condensing

Outputs

Linear 4-20 mA DC

Input Voltage

11.5-28 VDC

Power Consumption

<2 watts @ 24 VDC

Electrical Classification

Explosion proof

Class I, Division 1, Groups B, C, D

Safety Approvals

CSA and UL Approved

Sensor Life/Warranty

Sensor: 5 year warranty pro-rated

Transmitter: 2 year warranty

DIMENSIONS

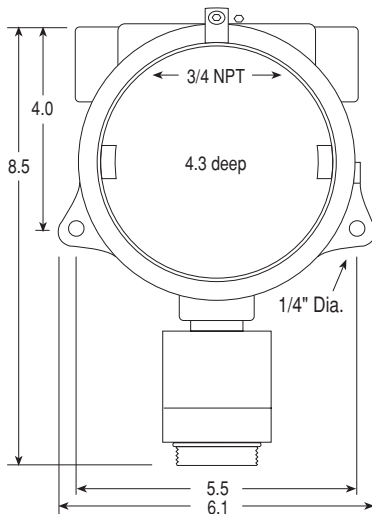

Splashguard 2"H x 2"Dia.

Non-dispersive
Infrared Optical

MicroSafe™ Intelligent Sensor

DESCRIPTION

Detcon Model IR-540 sensors are non-intrusive "Smart" sensors designed to detect and monitor Carbon Dioxide. Available ranges of detection are 0-0.3%, 0-1%, 0-3%, and 0-5% by volume. The sensor assembly consists of a miniature infrared optical sensor in a stainless steel housing that includes a splashguard with integral cal port, a plug-in control transmitter circuit, a base connector board and an explosion proof enclosure.

FEATURES

- ▶ CSA and UL Approved: Class I, Division 1, Groups B, C, & D
- ▶ Simple menu driven calibration - takes less than 3 minutes
- ▶ Backlit LCD and LED indicators for FAULT and CAL status
- ▶ Unique miniature field-replaceable optical sensor
- ▶ Plug-in field-replaceable transmitter
- ▶ Low power consumption
- ▶ 5-year expected sensor life

ORDER GUIDE

PN 965-405420-___ Model IR-540 in Aluminum Junction Box
PN 965-40542B-___ Model IR-540-316SS in Stainless Steel Junction Box

Complete the part number by choosing range

- 005 = 5%
- 003 = 3%
- 001 = 1%
- 0X3 = 0.3%



www.detcon.com