



MODEL IR-522

COMBUSTIBLE GAS SENSOR

ISO 9001:2008
Certified

888-367-4286
713-559-9200
fax 281-292-2860
www.detcon.com
sales@detcon.com

SPECIFICATIONS

Sensor Type

Non-dispersive Infrared Optical (NDIR)

Measurement Range

0-100% (lower explosive limit) LEL

Accuracy/Repeatability

±3% full scale 0-50% LEL
±5% full scale 50-100% LEL

Response/Clearing Time

T90 <30 seconds

Zero Drift

<5% per year

Operating Temperature Range

-40°F to +167°F; -40°C to +75°C

Operating Humidity Range

0-99% RH non-condensing

Outputs

Linear 4-20 mA DC

Input Voltage

11.5-28 VDC

Power Consumption

<2 watts @ 24 VDC

Electrical Classification

Explosion proof
Class I, Division 1, Groups B, C, D

Safety Approvals

CSA and UL Approved

Sensor Life/Warranty

Sensor: 5 year warranty pro-rated
Transmitter: 2 year warranty

DIMENSIONS

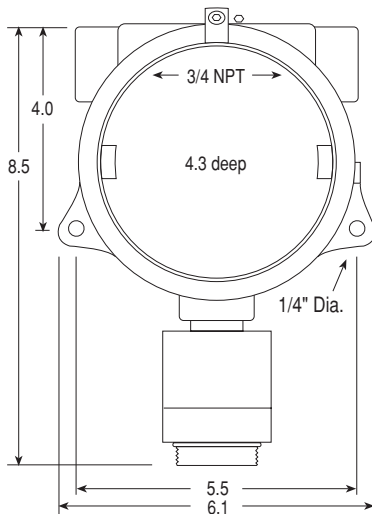

Splashguard 2"H x 2"Dia.

Non-dispersive
Infrared Optical

MicroSafe™ Intelligent Sensor

DESCRIPTION

Detcon Model IR-522 sensors are non-intrusive "Smart" sensors designed to detect and monitor Combustible Hydrocarbons over the range of 0-100% LEL (lower explosive limit). The sensor assembly consists of a miniature infrared optical sensor in a stainless steel housing that includes a splashguard with integral cal port, a plug-in control transmitter circuit, a base connector board and an explosion proof enclosure.

FEATURES

- ▶ CSA and UL Approved: Class I, Division 1, Groups B, C, & D
- ▶ Simple menu driven calibration - takes less than 3 minutes
- ▶ Backlit LCD and LED indicators for FAULT and CAL status
- ▶ Unique miniature field-replaceable optical sensor
- ▶ Plug-in field-replaceable transmitter
- ▶ Low power consumption
- ▶ 5-year expected sensor life

ORDER GUIDE

- PN 965-225420-100 Model IR-522 in Aluminum Junction Box
- PN 965-22542B-100 Model IR-522-316SS in Stainless Steel Junction Box



www.detcon.com