



# MODEL DM-500-C2H5OH

## ETHANOL SENSOR ASSEMBLY

ISO 9001:2008  
Certified

888-367-4286  
713-559-9200  
fax 281-292-2860  
www.detcon.com  
sales@detcon.com

## SPECIFICATIONS

- Sensor Type**  
Electrochemical Fuel Cell
- Measurement Range**  
0-100 ppm Ethanol  
Other ranges available
- Repeatability**  
±2% FS
- Response/Clearing Time**  
T90 <140 seconds
- Span Drift**  
<5% signal loss per year
- Operating Temperature Range**  
-20°C to +50°C; -4°F to +122°F
- Operating Humidity Range**  
15-90% RH non-condensing
- Output**  
Linear 4-20 mA DC
- Input Voltage**  
11.5-28 VDC
- Power Consumption**  
1.6 watts @ 24 VDC
- Electrical Classification**  
Explosion proof  
Class 1, Div. 1, Groups B, C, D
- Sensor Life/Warranty**  
Sensor: 2 year warranty  
Transmitter: 2 year warranty
- Safety Approvals**  
CSA and UL Approved

## DIMENSIONS

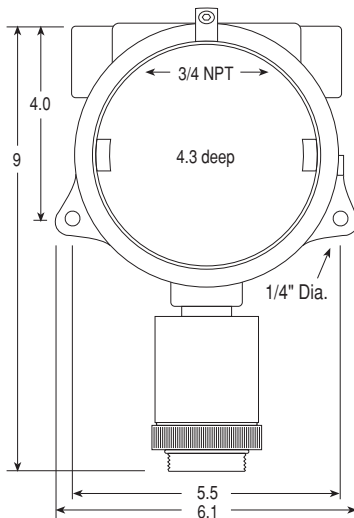

Splashguard 2"H x 2"Dia.

## Electrochemical Fuel Cell

## MicroSafe™ Intelligent Sensor

## DESCRIPTION

Detcon Model DM-500IS-C2H5OH sensor is designed to detect and monitor C2H5OH in air over the range 0-100 ppm. The sensor assembly consists of an electrochemical fuel cell mounted in an Intrinsically Safe stainless steel and ABS plastic housing that includes a splashguard with integral cal port, a signal conditioning control transmitter circuit, a base connector board and an explosion proof junction box. The Intrinsically Safe sensor housing design allows direct contact of the target gas to the electrochemical sensor, thus maximizing response time, detectability and repeatability. And because the Intrinsically Safe housing design does not use a stainless steel flame arrester, it eliminates inaccurate readings due to target gas absorption.

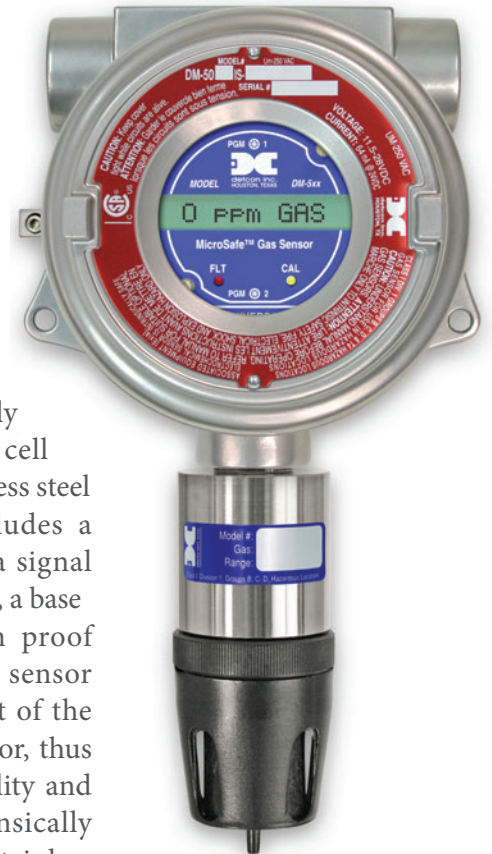

## FEATURES

- ▶ CSA and UL Approved: Class 1, Div. 1, Groups B, C, & D
- ▶ 4-20 mA output
- ▶ Simple menu driven calibration - takes less than 3 minutes
- ▶ Backlit LCD, and LED indicators for Fault, and Cal status
- ▶ Universal plug-in transmitter
- ▶ Intrinsically Safe Sensor Housing
- ▶ Plug-in field-replaceable transmitter
- ▶ Electrochemical plug-in sensor

## ORDER GUIDE

- PN 965-12EO80-100    DM-500IS-C2H5OH in Aluminum Junction Box
- PN 965-12EO8B-100    DM-500IS-C2H5OH in Stainless Steel Junction Box

[www.detcon.com](http://www.detcon.com)